

HKTA 1003  
ISSUE 4  
February 2003

**PERFORMANCE SPECIFICATION  
FOR PRIVATE FIXED LINK EQUIPMENT  
WITH A CAPACITY OF 12 OR 24  
FDM-FM CHANNELS IN THE  
FREQUENCY BAND 1429 - 1530 MHz**



**Telecommunications Authority  
Hong Kong**

## FOREWORD

1. This specification is prescribed under section 32D of the Telecommunications Ordinance (Cap 106) (“the Ordinance”) to set out the technical and evaluation requirements for 12 or 24 channels FDM-FM fixed link radio equipment operating in the 1.5 GHz band. Radiocommunications apparatus falling into the scope of this specification shall meet the stipulated requirements.
2. Under the Ordinance, the possession or use of any radiocommunications apparatus or any apparatus emitting radio frequency energy must be covered by an appropriate licence issued by the Telecommunications Authority (TA) with the exception of those specifically exempted from licensing under the Ordinance, such as those covered by the Telecommunications (Telecommunications Apparatus)(Exemption from Licensing) Order.
3. At present, the Office of the Telecommunications Authority (OFTA) operates a **Hong Kong Telecommunications Equipment Evaluation and Certification (HKTEC) Scheme**. Details of the HKTEC Scheme can be found in the information note OFTA I 421. Under the Scheme, suppliers or manufacturers of the radiocommunications apparatus shall apply to OFTA for certification of their apparatus against this specification. The application procedures for certification of radiocommunications apparatus can be found in the information note OFTA I 401.
4. The TA reserves the right to give separate certification to models he considers to be technical variants and the performance of which may differ between models.
5. The TA may amend any part of this specification as and when he deems necessary.
6. In case of doubt about the interpretation of this specification, the methods of carrying out the test and the validity of statements made by the equipment manufacturers or suppliers about the equipment, the decision of the TA shall be final.
7. The HKTA specifications and information notes are issued by the TA. The documents can be obtained through one of the following methods —
  - downloading direct through the OFTA's Internet Home Page. The Home Page address is <http://www.ofa.gov.hk>;
  - making a request for hard copies to :-

Radio Laboratory,  
Standards Section,  
Office of the Telecommunications Authority,  
29/F Wu Chung House,  
213 Queen’s Road East,  
Wanchai,

Hong Kong.

Fax: +852 2343 5824

Email: radiolab@ofta.gov.hk

8. Enquiries about this specification may be directed to —

Radio Laboratory, Standards Section,  
Office of the Telecommunications Authority,  
29/F Wu Chung House,  
213 Queen's Road East, Wanchai, Hong Kong.

Fax : +852 2343 5824

Email: radiolab@ofta.gov.hk

## AMENDMENT TABLE

Item	Issue No.	Paragraph	Descriptions
1.	Issue 4 February 2003	Foreword	Add information of HKTEC Scheme and other editorial changes.

## **CONTENT**

- 1 GENERAL
  - 1.1 Scope of specification
  - 1.2 Operating frequency
  - 1.3 Model number
  
- 2 THE CONDITIONS: ATMOSPHERIC CONDITIONS AND POWER SUPPLIES
  - 2.1 General
  - 2.2 Normal test conditions
  - 2.3 Extreme test conditions
  - 2.4 Procedures for tests at extreme temperatures
  
- 3 ELECTRICAL TEST CONDITIONS
  - 3.1 Standard test signal
  - 3.2 Transmitter loading conditions
  - 3.3 Receiver input signal
  - 3.4 Receiver mute or squelch facility
  - 3.5 Noise Power Radio
  
- 4 TRANSMITTER TESTS
  - 4.1 Carrier power
  - 4.2 Frequency error
  - 4.3 Spurious emissions
  - 4.4 Radiated spectrum
  
- 5 RECEIVER TESTS
  - 5.1 Reference sensitivity
  - 5.2 Selectivity
  - 5.3 Spurious response rejection
  - 5.4 Receiver spurious emissions

## **1 GENERAL**

### **1.1 Scope of specification**

This specification covers the minimum performance requirements of 12 and 24 channels FDM-FM radio link equipment operating in the 1.5 GHz band.

### **1.2 Operating frequency**

The equipment shall provide for transmission and reception of emissions in the frequency range 1429 MHz to 1530 MHz. The precise operating frequencies shall be granted by the Authority for each individual application.

### **1.3 Model number**

The equipment shall be provided with a clear indication of the model number that all the production samples will use. In case where the Authority finds two manufacturers have used the same model number, one manufacturer will be asked to change that model number.

## **2 TEST CONDITIONS : ATMOSPHERIC CONDITIONS AND POWER SUPPLY**

### **2.1 General**

Type approval tests shall be made under normal test conditions and also, where stated, under extreme test conditions.

### **2.2 Normal test conditions**

#### **2.2.1 Atmospheric testing conditions**

The normal atmospheric conditions for all the tests shall be, as far as possible, maintained at any convenient combination of temperature and humidity within the following ranges:-

1. Temperature : +15°C to +35°C
2. Relative Humidity : 20% to 75%C

## 2.2.2 Test power source

### 2.2.2.1 General

The power supply for the equipment under test may be replaced by a test power source, capable of producing normal and extreme test voltages as specified below.

### 2.2.2.2 Mains source voltage

For the equipment powered by AC mains, 220V  $\pm$  6% at frequency 50 Hz  $\pm$  1 Hz shall be designated as the test voltage.

### 2.2.2.3 D.C. test source voltage

For the equipment operated by batteries, either primary or secondary or any other d.c. sources, the normal test source voltage shall be that declared by the manufacturer.

## 2.3 Extreme test conditions

### 2.3.1 Extreme temperatures

For tests at extreme temperatures, measurements shall be made in accordance with the procedures specified in Clause 2.4 at an upper value of +55°C and at a lower value of +2°C.

### 2.3.2 Extreme mains source voltage

The extreme mains source voltage shall be  $\pm$  10% of the normal mains source voltage at frequency 50 Hz  $\pm$  1 Hz.

### 2.3.3 Extreme d.c. test source voltage

The extreme d.c. test source voltage shall be  $\pm$ 10% of the d.c. test source voltage declared by the equipment manufacturer.

## 2.4 Procedure for tests at extreme temperatures

### 2.4.1 General

Before making measurements, the equipment, which is switched off, shall be placed in a temperature controlled chamber for a period of one hour for temperature stabilization. The humidity content in the test chamber shall be controlled so that excessive condensation does not occur.

2.4.2 Test procedure

For tests at the upper temperature, after thermal balance has been attained (Clause 2.4.1), the equipment shall be switched on in the transmit condition for half an hour after which the appropriate tests shall be carried out.

For tests at the lower temperature, after thermal balance has been attained (Clause 2.4.1), the equipment shall be switched on in the receive or transmit condition for one minute after which the appropriate tests shall be carried out.

Note: If the equipment contains temperature stabilization circuits designed to operation continuously, the equipment may be switched on for 15 minutes before measurements are made.

### 3 ELECTRICAL TEST CONDITIONS

#### 3.1 Standard test signal

3.1.1 The standard test signal shall comprise a radio frequency carrier frequency modulated by a band-limited uniform spectrum noise signal and which shall be capable of being suppressed by 70 dB or more in two in-band measuring channels. Table 1 shows the band limits of the noise signal, its level and the measuring channel frequencies for capacities of 12 and 24 channels.

telephone channel capacity	maximum per chan. deviation (kHz)	noise band (kHz)	noise power (dB)*	centre freq. of measuring chans. (kHz)	
				upper	lower
12	35	12-60	+4.8	56	16
24	35	12-108	+5.4	98	16

Table 1 : Limits of noise signal

\*NOTE : Relative to the level of a single sinusoidal modulating signal of frequency 800 Hz which will cause the radio frequency carrier to have a frequency deviation equal to the per-channel frequency deviation quoted by the equipment manufacturer.

3.1.2 The transmitter under test, modulated in accordance with 3.1.1 and its output suitably attenuated, may be used as the test signal for receiver measurements provided that the transmit and receive frequency are the same.

### **3.2 Transmitter loading conditions**

The transmitter antenna output shall be terminated with a non-reactive, non-radiating load of 50 ohms. If the transmitter output impedance is different from 50 ohms, the manufacturer should provide suitable matching device for type-testing purpose.

### **3.3 Receiver input signal**

The test signals applied to the receiver input shall be connected such that the source impedance seen from the receiver input terminals is 50 ohms, irrespective of one or more signals applied to the receiver simultaneously.

The levels of the test signals shall be expressed in terms of the power in dBW at the receiver input port.

The effect of any intermodulation products or noise produced in the test equipment shall be negligible.

### **3.4 Receiver mute or squelch facility**

If the receiver is equipped with a mute or squelch circuit, this shall be made inoperative for the duration of the type approval test.

### **3.5 Noise Power Ratio (NPR)**

Noise Power Ratio is a measurement for radio link system carrying multichannel FDM-FM information. NPR is defined as the ratio, expressed in dB, of the noise in a test channel with all channels loaded with white noise to noise in the test channel with all other channels fully noise loaded except the test channels.

## **4 TRANSMITTER TESTS**

### **4.1 Carrier power**

#### **4.1.1 Definition**

The carrier power of a transmitter is the average power available at the output terminals of the equipment during one radio frequency cycle in the absence of modulation.

#### 4.1.2 Method of measurement

The transmitter output port shall be connected to the normal load condition specified by the manufacturer and with means to measure the power delivered to the load. Figure 1 refers.

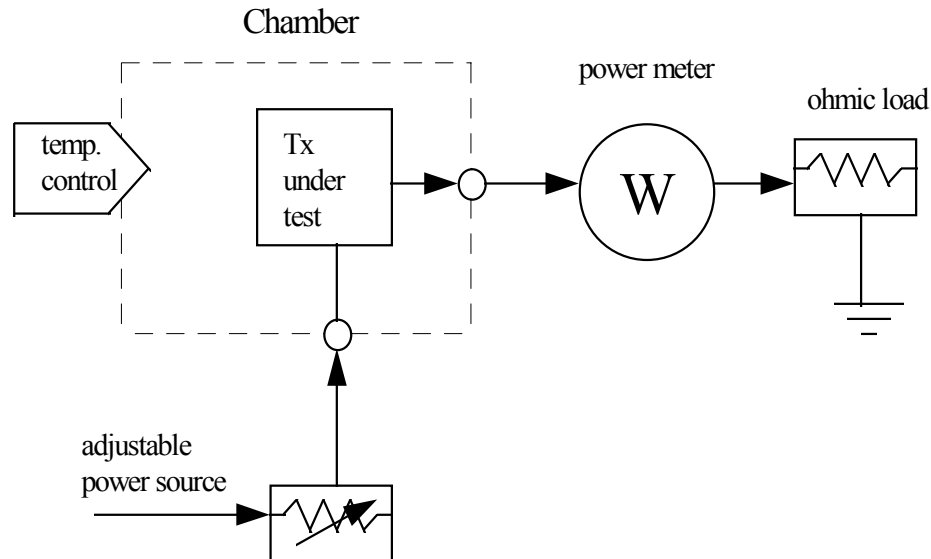

**Figure 1 : Carrier power test arrangement**

In the absence of modulation, the maximum carrier power shall be measured under normal test conditions (Clause 2.2) and repeated under extreme test conditions (Clause 2.3 and 2.4).

#### 4.1.3 Minimum standard

The carrier output power shall be within  $\pm 2$  dB of the manufacturer's maximum rated output power under any test conditions.

### 4.2 Frequency error

#### 4.2.1 Definition

The frequency error of the transmitter is the difference between the measured carrier frequency and its nominal value.

#### 4.2.2 Method of measurement

The transmitter under test shall be connected as shown in Figure 2 and operated in accordance with the manufacturer's instruction to obtain the normal output power. In the absence of modulation, the carrier frequency shall be measured under normal

test conditions (Clause 2.2) and repeated under extreme test conditions (Clause 2.3 & 2.4)

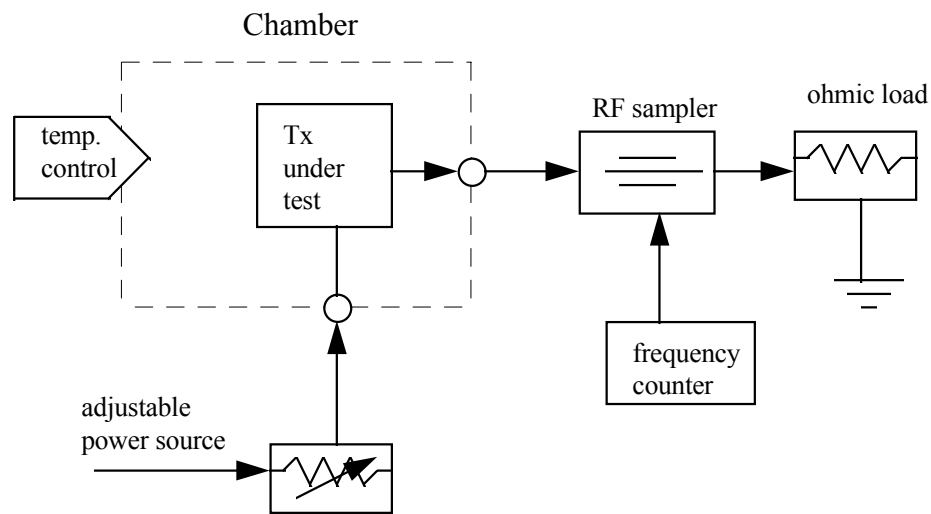

**Figure 2 : Frequency error test arrangement**

#### 4.2.3 Minimum standard

The maximum permissible frequency error, under both normal and extreme conditions, shall be  $\pm 15$  KHz

### 4.3 Spurious emissions

#### 4.3.1 Definition

Spurious emissions are those radio frequency emissions which are outside the necessary bandwidth and the level of which may be reduced without affecting the corresponding transmission of information.

(NOTE : Spurious emissions include harmonic emissions, parasitic emissions, intermodulation products and frequency conversion products)

#### 4.3.2 Method of measurement

The transmitter output port shall be connected to a spectrum analyser via a suitable attenuator as shown in Figure 3.

The transmitter shall be unmodulated and at each spurious emission up to 10 GHz, the power level of the emission shall be measured accordingly.

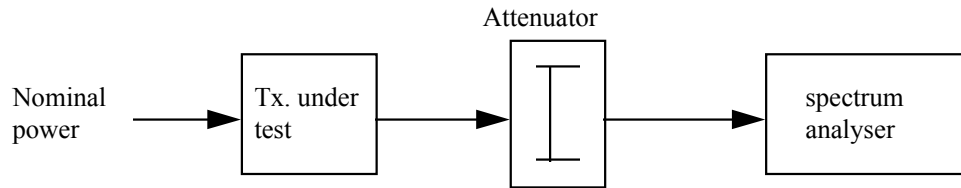

**Figure 3 : Spurious emission test arrangement**

4.3.3 Minimum standard

The power level of any spurious emission in the frequency range 0-10 GHz shall not exceed - 56 dBW (i.e. 2.5  $\mu$ W)

**4.4 Radiated spectrum**

4.4.1 Definition

It is the emitted spectrum when the transmitter is modulated by a band-limited uniform spectrum noise signal specified in Table 1.

4.4.2 Method of measurement

The transmitter output port shall be connected to a spectrum analyser via a suitable attenuator as shown in Figure 4. The spectrum analyser shall have variable persistence display for record purpose and its controls shall be adjusted as follows:-

- |    |                     |   |                               |
|----|---------------------|---|-------------------------------|
| 1. | RF centre frequency | - | Transmitter Carrier Frequency |
| 2. | IF bandwidth        | - | 10 KHz                        |
| 3. | Sweep Width         | - | 100 KHz per division          |
| 4. | Amplitude Scale     | - | Logarithmic 10 dB/division    |
| 5. | Scan Time           | - | 0.1 seconds/division          |
| 6. | Video Filter        | - | 100 Hz                        |

With the unmodulated carrier, the spectrum analyser attenuator controls shall be adjusted such that the amplitude is set to a convenient datum level.

A band limited uniform spectrum noise signal shall be applied to the transmitter and the emitted spectrum is recorded.

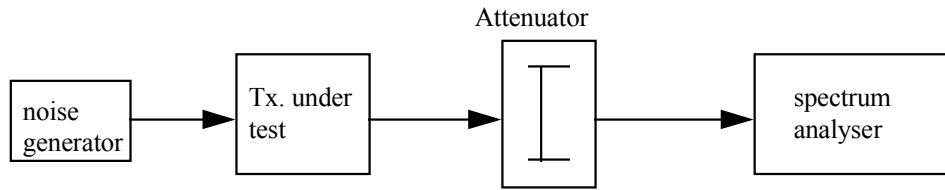

**Figure 4 : Radiated Spectrum test arrangement**

#### 4.4.3 Minimum standard

The radiated spectrum shall be such that all emissions are within the boundary as shown in Figure 5.

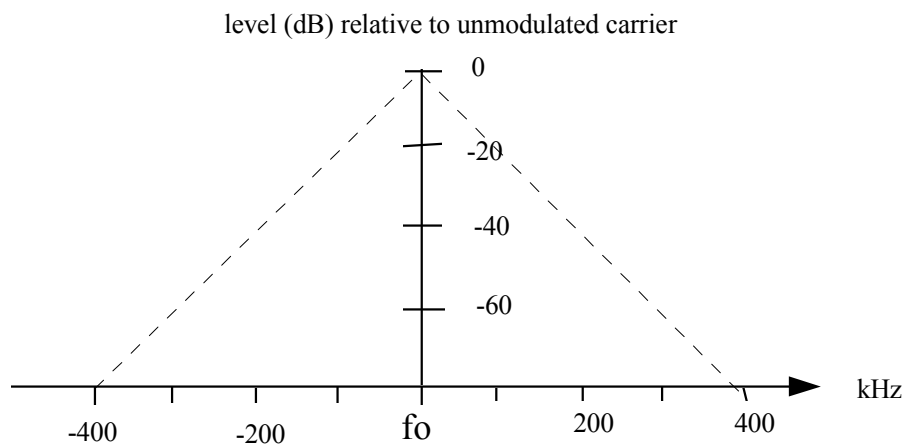

**Figure 5 : Limit on the radiated spectrum**

## 5 RECEIVER TEST

### 5.1 Reference sensitivity

#### 5.1.1 Definition

The reference sensitivity of the receiver is the minimum signal level at the receiver input, at the nominal frequency of the receiver and with the normal test modulation, that will produce at the output of the receiver a signal of a given quality which is measured in terms of the Noise Power Ratio in specified telephone channels.

#### 5.1.2 Method of measurement

With the equipment set up as shown in Figure 6, the standard test signal (Clause 3.1) at the nominal frequency of the receiver shall be applied to the receiver input port at a level of - 80 dBW.

The noise receiver shall be set to measure in the upper measuring channel. Without noise suppression in the measuring channel, the attenuator control of the noise receiver shall be adjusted to an arbitrary reading ( $x$ ) to give a convenient datum indication which shall also be recorded for later use.

With noise suppression in the measuring channel, the attenuator control of the noise receiver shall be re-adjusted ( $y$ ) to restore the same datum indication.

The difference in noise receiver attenuator settings  $x$  and  $y$  is the upper channel noise power ratio.

The above procedure shall be repeated but with measurements being made in the lower measuring channel.

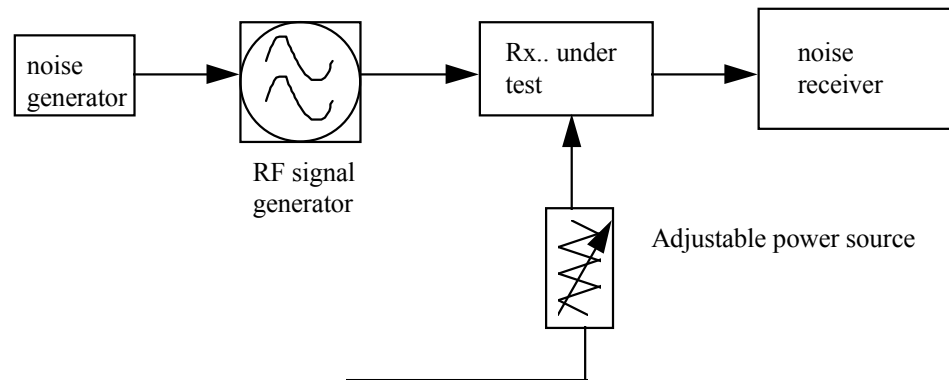

**Figure 6 : Reference sensitivity test arrangement**

### 5.1.3 Minimum Standard

The noise power ratios in the measuring channels shall not be less than 52 dB for both 12 and 24 channels capacity.

## 5.2 Selectivity

### 5.2.1 Definition

The selectivity of the receiver is the ability to receive a wanted modulated signal of a given quality in the presence of an unwanted signal.

### 5.2.2 Method of measurement

The equipment set up is arranged as in Figure 7.

Signal generator A shall be tuned to the nominal frequency of the receiver and set to a level of -80 dBW. This standard test signal constitutes the wanted signal.

A standard 24 channel test signal (Clause 3.1 but without the need for suppressing the modulating signal) shall be applied to the receiver through signal generator B. Signal generator B shall be tuned to a frequency 1000 KHz above the nominal frequency of the receiver and set to a level of -100 dBW. This signal constitutes the unwanted signal.

The noise power ratio in the upper measuring channel of the receiver output shall be determined and recorded.

With the unwanted carrier set to a frequency 1000 KHz below the nominal frequency of the receiver, the noise power ratio in the upper measuring channel shall be repeated.

The above procedure shall be repeated with unwanted signal set to other offset frequencies and their corresponding levels are shown in Table 2.

unwanted signal frequency off-set (kHz)	unwanted signal input level (dBW)
±1000	-100
±1500	-90
±2000	-80

**Table 2 : Characteristics of unwanted signal**

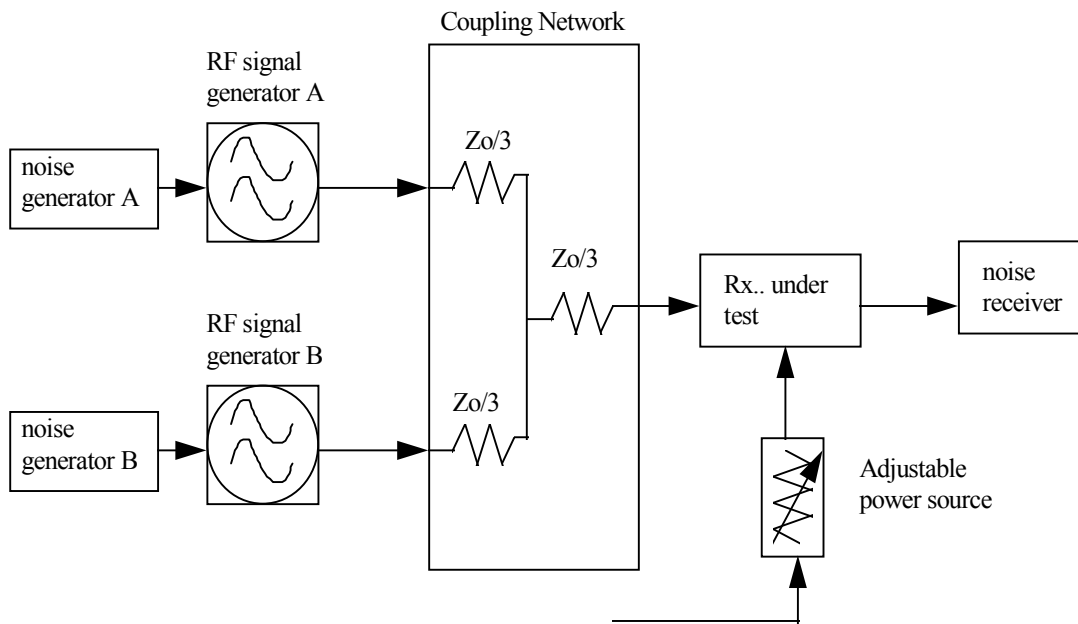

$Z_o$  : nominal impedance of receiver

**Figure 7 : Selectivity test arrangement**

### 5.2.3 Minimum standard

For any of the unwanted signal of Table 2, the noise power ratio shall not be less than 52 dB.

## 5.3 Spurious response rejection

### 5.3.1 Definition

The spurious response rejection ratio of the receiver is a measure of its ability to discriminate between the wanted signal at the nominal frequency of the receiver and an unwanted signal at any other frequency at which a response is obtained.

### 5.3.2 Method of measurement

1. The equipment is set up as shown in Figure 8.
2. The noise receiver, with its attenuator control set as in Clause 5.1.2, shall be connected to the receiver output port.
3. In the absence of modulation, the signal generator shall be tuned to the nominal frequency of the receiver and set to a level of -120 dBW.
4. The upper channel noise power ratio, in dB relative to the datum established in Clause 5.1.2, shall be determined and recorded.
5. The level of the unmodulated signal source shall be adjusted to -60 dBW and the frequency shall be varied from the lowest intermediate frequency of the receiver to 2000 MHz.
6. At each frequency at which a receiver "quietening" is observed, the upper channel noise power ratio, in dB relative to the datum established in Clause 5.1.2 shall be measured and recorded.

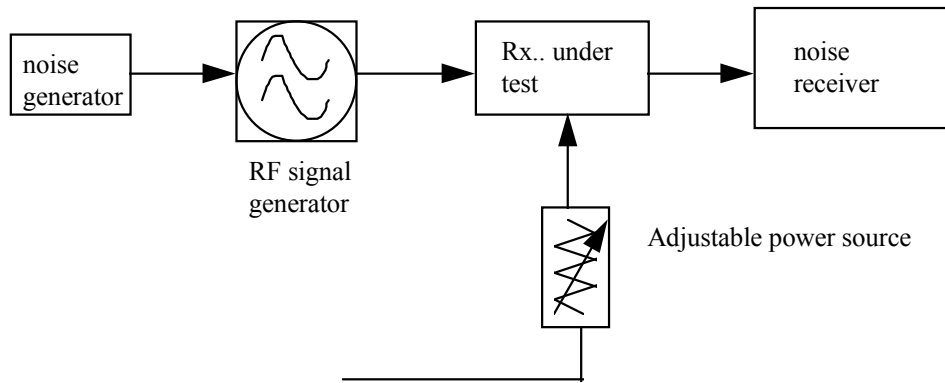

**Figure 8 : Test arrangement for spurious response rejection**

### 5.3.3 Minimum Standard

At any frequency separated from the receive frequency by more than 2000 KHz, the noise power ratio recorded in 5.3.2 (f) shall not exceed that recorded in 5.3.2(d).

## 5.4 Receiver spurious emissions

### 5.4.1 Definition

Spurious emission from the receiver are any unwanted emissions present at its input port.

### 5.4.2 Method of measurement

With the receiver input port connected to a spectrum analyser, the power level of each emission up to 10 GHz shall be measured.

### 5.4.3 Minimum standard

The power of any spurious emission in the frequency range 0-10 GHz shall not exceed -77 dBW (20 nW).

**- END -**