

HKTA 1019
ISSUE 3
NOVEMBER 2011

**PERFORMANCE SPECIFICATION
FOR TV ANTENNA AMPLIFIERS**



**TELECOMMUNICATIONS AUTHORITY
HONG KONG**

FORWARD

1. This specification is issued pursuant to Section 32D of the Telecommunications Ordinance (Cap. 106). This specification sets out the technical requirements for TV antenna amplifiers in Hong Kong.
2. Under the Ordinance, the possession or use of any radiocommunications apparatus or any apparatus emitting radio frequency energy must be covered by an appropriate licence issued by the Telecommunications Authority (TA) with the exception of those specifically exempted from licensing under the Ordinance.
3. At present, the Office of the Telecommunications Authority (OFTA) operates a Hong Kong Telecommunications Equipment Evaluation and Certification (HKTEC) Scheme. Details of the HKTEC Scheme can be found in the information note OFTA I 421. Under the Scheme, suppliers or manufacturers shall apply for certification of their apparatus against this specification. The application procedures for certification of radiocommunications apparatus can be found in the information note OFTA I 401.
4. The TA may amend any part of this specification as and when he deems necessary.
5. In case of doubt about the interpretation of this specification, the methods of carrying out the test and the validity of statements made by the manufacturers of the equipment, the decision of the TA shall be final.
6. The HKTA specifications and information notes issued by the TA can be obtained from OFTA's website at <http://www.ofta.gov.hk>. Enquiries about this specification can be directed to -

Senior Telecommunications Engineer
Standards Section
Office of the Telecommunications Authority
29/F Wu Chung House
213 Queen's Road East
Wanchai
Hong Kong

Fax: +852 2838 5004

Email: standards@ofta.gov.hk

AMENDMENT TABLE

Item	Issue No.	Paragraph	Descriptions
1.	Issue 3 November 2011	Foreword	Editorial changes are incorporated to align with other HKTA specifications.
2.	Issue 3 November 2011	Amendment table and content	Add the amendment table and the content.
3.	Issue 3 November 2011	Paragraphs 4.1.1 and 4.1.2	Update the TV broadcast frequency range from 470-790 MHz to 470-806 MHz to align with the Hong Kong Table of Frequency Allocation.
4.	Issue 3 November 2011	Paragraph 4.1.2	Amend the requirement on gain/frequency response to clarify that the mean level at the equipment output is as specified by the manufacturer.
5.	Issue 3 November 2011	Paragraph 6	The original para. 6 on the interpretation of this specification is deleted as the statement is already included in the Foreword section.

CONTENT

1. SCOPE
2. GENERAL
3. TEST CONDITIONS
4. TECHNICAL REQUIREMENTS
5. ACCURACY OF MEASUREMENT

1. SCOPE

This specification stipulates the minimum technical performance for TV antenna amplifier that is required to reduce potential interference to television reception and other radio telecommunication services in Hong Kong. Improvement of picture quality and safety requirements are beyond the scope of this specification.

2. GENERAL

- 2.1 The amplifier shall be provided with a clear indication of the type number and description under which it is submitted for testing. Each type number shall be unique.
- 2.2 For outdoor installation type, the mast head unit of the antenna amplifier shall be able to be affixed firmly to the associated structures. All out-door unit containing electrical contacts shall be carefully protected from rain.
- 2.3 The amplifier shall at all times be operated in such a manner that it does not cause interference to reception of television broadcast and other authorised telecommunication services. Those controls, which may increase the interfering potentialities of the amplifier if maladjusted, shall not be easily accessible.
- 2.4 The amplifier shall be so designed that it will remain in compliance with the requirements of this specification throughout its serviceable life.

3. TEST CONDITIONS

- 3.1 The amplifier under test shall be installed and adjusted in accordance with the relevant instructions.
- 3.2 In case the amplifier incorporates an user adjustable gain control, this control shall be adjusted for maximum gain of the amplifier.
- 3.3 All testing equipment shall be arranged to match an impedance of 75 ohms.
- 3.4 Unless otherwise specified, measurements shall be made under the following environmental test conditions -
 - i. the ambient temperature external to the equipment cabinet between 0°C and +45°C;
 - ii. the external relative humidity up to 95%;
 - iii. the mains supply voltage variation $\pm 10\%$;
 - iv. the mains supply frequency variation of $\pm 5\%$.

4. TECHNICAL REQUIREMENTS

The TV antenna amplifier shall meet the following technical requirements -

4.1 GAIN/FREQUENCY RESPONSE

4.1.1 Method of Measurement

- i. An r.f. signal of 50 μ V shall be applied to the input terminal of the amplifier under test. The output terminals of the amplifier shall be monitored.
- ii. The frequency of signal generator shall sweep over a range of 470 MHz to 806 MHz -

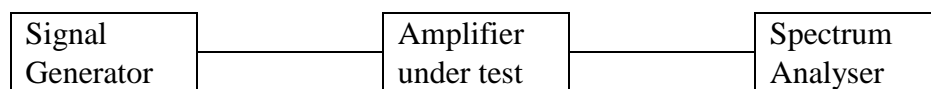

4.1.2 Limit

The amplitude response as a function of frequency at the output terminals of the amplifier shall not deviate from the mean level as specified by the manufacturer by 3.5 dB over the frequency range of 470 MHz to 806 MHz.

4.2 INTERMODULATION RESPONSE REJECTION

4.2.1 Method of measurement

- i. Signal generators A and B shall be set at frequencies of 279 MHz and 281 MHz respectively.
- ii. The levels of both generators shall be kept equal and adjusted until the largest second order intermodulation product reaches a level of -70 dBm.
- iii. Frequencies of the signal generators A and B shall then be changed to 171 MHz and 173 MHz respectively. The levels of both generators shall be adjusted again until the largest third order intermodulation product reaches a level of -70 dBm.
- iv. The levels of signal generators across the input terminals of antenna amplifier shall be recorded, which is the intermodulation response rejection of the amplifier.

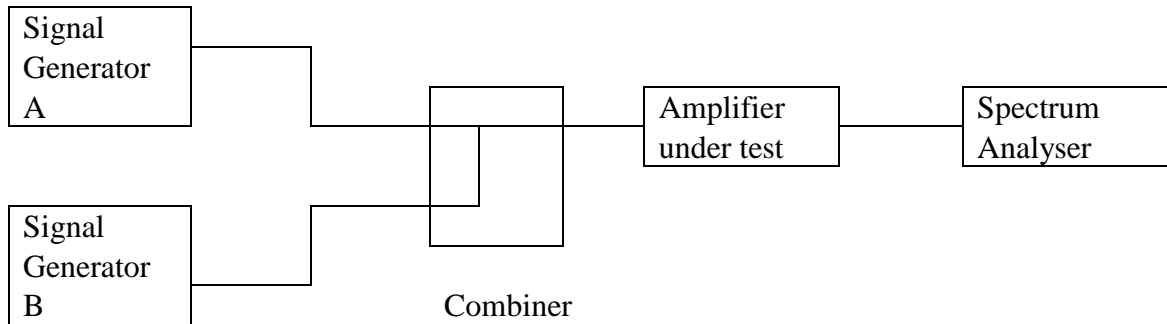

4.2.2 Limit

The intermodulation response rejection at 280 MHz and 172 MHz shall not be less than -30 dBm and -27 dBm respectively.

5. ACCURACY OF MEASUREMENT

5.1 The tolerance of the measurement of the following parameters shall be as follows -

5.1.1	AC mains voltage	±3%
5.1.2	AC mains frequency	±0.5%
5.1.3	Radio frequency	±50 Hz
5.1.4	Radio frequency voltage	±2 dB
5.1.5	Radio frequency power	±2 dB
5.1.6	Impedance of combining units, matching units, cables, plugs attenuators etc.	±5%
5.1.7	Source impedance of generators and input impedance of measuring equipment	±10%
5.1.8	Attenuation of attenuators	±0.5 dB
5.1.9	Temperature	±1°C
5.1.10	Relative humidity	±5%

- END -