

**PERFORMANCE SPECIFICATION FOR
27MHz CITIZEN BAND (CB)
RADIO TRANSCEIVERS
FOR USE ON-BOARD FISHING VESSELS**



**Telecommunications Authority
Hong Kong**

FOREWORD

1. This specification is prescribed under section 32D of the Telecommunications Ordinance (Cap 106) (“the Ordinance”) to set out the technical and evaluation requirements for 27 MHz band Citizen Band (CB) radio transceivers for use on-board fishing vessels in Hong Kong. Radiocommunications apparatus falling into the scope of this specification shall meet the stipulated requirements.
2. Under the Ordinance, the possession or use of any radiocommunications apparatus or any apparatus emitting radio frequency energy must be covered by an appropriate licence issued by the Telecommunications Authority (TA) with the exception of those specifically exempted from licensing under the Ordinance, such as those covered by the Telecommunications (Telecommunications Apparatus)(Exemption from Licensing) Order.
3. At present, the Office of the Telecommunications Authority (OFTA) operates a Hong Kong Telecommunications Equipment Evaluation and Certification (HKTEC) Scheme. Details of the HKTEC Scheme can be found in the information note OFTA I 421. Under the Scheme, suppliers or manufacturers of the radiocommunications apparatus shall apply to OFTA for certification of their apparatus against this specification. The application procedures for certification of radiocommunications apparatus can be found in the information note OFTA I 401.
4. The TA reserves the right to give separate certification to models he considers to be technical variants and the performance of which may differ between models.
5. The TA may amend any part of this specification as and when he deems necessary.
6. In case of doubt about the interpretation of this specification, the methods of carrying out the test and the validity of statements made by the equipment manufacturers or suppliers about the equipment, the decision of the TA shall be final.
7. The HKTA specifications and information notes are issued by the TA. The documents can be obtained through one of the following methods —
 - downloading direct through the OFTA's Internet Home Page. The Home Page address is <http://www.ofta.gov.hk>;
 - making a request for hard copies to :-

Radio Laboratory,
Standards Section,
Office of the Telecommunications Authority,
29/F Wu Chung House,
213 Queen’s Road East,
Wanchai,
Hong Kong.

Fax: +852 2343 5824
Email: radiolab@ofta.gov.hk

8. Enquiries about this specification may be directed to —

Radio Laboratory, Standards Section,
Office of the Telecommunications Authority,
29/F Wu Chung House,
213 Queen's Road East, Wanchai, Hong Kong.

Fax : +852 2343 5824
Email: radiolab@ofta.gov.hk

AMENDMENT HISTORY

Item	Issue No.	Paragraph	Descriptions
1.	Issue 3 February 2003	Foreword	Add information of HKTEC Scheme and other editorial changes.

CONTENTS

1. General
2. Test Conditions: Atmospheric Conditions and Power Supplies
3. Test Conditions: Electrical
4. Tests
5. Accuracy of Measurements

FIGURES

Explanation notes for figures 2 and 3

Figure 1 : 3-metre Test Site

Figure 2 : Radiation Measurement (Using Test Antenna)

Figure 3 : Radiation Measurement (Using Substitution Antenna)

Figure 4 : Transmitter Carrier Power Test Arrangement

Figure 5 : Transmitter Spurious Emission Test Arrangement

Figure 6 : Receiver Spurious Emissions at Antenna Terminals

ANNEX

Annex 1 : Channelling Plan

1. GENERAL

1.1 Scope of specification

This specification covers the minimum performance requirements for CB radio transceivers for use on-board fishing vessels.

1.2 Operating Frequencies

The operating frequencies of the equipment shall conform to the channelling plan specified in Annex 1. The channel spacing is 10 kHz. The equipment shall not be capable of operating at frequencies other than those specified in Annex 1.

1.3 Modulation

Any one of the following modulation methods will be acceptable :-

1. Frequency modulation
2. Phase modulation
3. Double sideband amplitude modulation
4. Single sideband amplitude modulation

1.4 Application

Only equipment designed for fixed installation on a vessel will be accepted. Portable equipment will not be accepted.

1.5 Transmitter output power

The output power of transmitter operating in the mode of frequency modulation, phase modulation or double sideband amplitude modulation shall be the measure of carrier power of the transmitter. The rated output power shall be the carrier power declared by the manufacturer and is limited to 10 watts.

The output power of transmitter operating in the mode of single sideband amplitude modulation shall be the measure of the peak envelope power delivered to an artificial load. The rated output power shall be the peak envelope power declared by the manufacturer and is limited to 12 watts.

1.6 Spurious emission of transmitter

The power of any spurious emission whether measured as output power level at the antenna terminals or effective radiated power in free space in the specified range of frequencies at either plane of polarization, shall not exceed 4 microwatts for amplitude modulation and 0.25 microwatt for frequency modulation and phase modulation.

1.7 Spurious emission of receiver

The power of any spurious emission whether measured as output power level at the antenna terminals or effective radiated power in free space shall not exceed 4 microwatts for amplitude modulation and 20 nanowatts for frequency modulation and phase modulation.

2. TEST CONDITIONS: ATMOSPHERIC CONDITIONS AND POWER SUPPLIES

2.1 General

Type approval tests shall be made under normal test conditions.

2.2 Normal Test Conditions

2.2.1 Normal temperature and humidity

The normal temperature and humidity conditions for tests shall be any convenient combination of temperature, humidity and air pressure within the following ranges :

Temperature	:	15 to 35 degrees Celsius
Relative humidity	:	10 to 80 percent
Air pressure	:	860 to 1060 hPa

When it is impracticable to carry out the tests under the conditions stated above, a note to this effect, stating the actual temperature and relative humidity during the tests, shall be added to the test report.

2.2.2 Mains voltage

For equipment powered by AC mains, 220V \pm 6% at frequency of 50 Hz \pm 1 Hz shall be designated as the normal test voltage.

2.2.3 DC test source voltage

For equipment supplied from self-contained primary cells or batteries or any dc source, the normal test source voltage shall be the nominal supply voltage declared by the manufacturer.

3. TEST CONDITIONS: ELECTRICAL

3.1 Normal Test Modulation

- 3.1.1 For frequency or phase modulation, the normal test modulation shall be a sinusoidal signal of frequency $1 \text{ kHz} \pm 1\%$ with harmonic distortion not more than 1% and the level adjusted to produce 60% of the maximum permissible frequency deviation.
- 3.1.2 For double sideband amplitude modulation, the normal test modulation shall be a sinusoidal signal of frequency 1 kHz and the level adjusted to produce a modulation depth of 60%.
- 3.1.3 For single sideband amplitude modulation, the modulating signal shall comprise two non-harmonically related sinusoidal tones, in the frequency range of 300 Hz to 3000 Hz inclusive, at a level required to establish the rated peak envelope power.

3.2 Transmitter Loading Conditions

The transmitter antenna output shall be terminated with a non-reactive, non-radiating load with nominal impedance of 50 ohms. In case the nominal impedance is of value other than 50 ohms, the manufacturer shall provide suitable matching devices for type-testing purpose.

3.3 General Requirements for Tests Involving the Use of Radiated Field

3.3.1 Test Site

- 1. The test site shall be flat and free of reflecting objects. No extraneous metal objects having any dimension in excess of 50 mm shall be in the immediate vicinity of the test sample or the test antenna used for measuring the radiation.
- 2. The test sample and the measuring equipment shall be located over a wire mesh ground screen of 9 m long and 6 m wide. The wire mesh shall be considered as the reference earth for the measuring system.
- 3. The distance between the centre of the vertical projection of the test sample in the horizontal plane and the centre of the test antenna shall be 3 m.
- 4. Figure 1 shows the arrangement of the on-site setup.

3.3.2 Test antenna

1. The test antenna is used to detect the radiation from both the test sample and the substitution antenna during radiation measurement. The antenna shall be mounted at the end of a horizontal boom supporting by a vertical pole, both made of non-conducting material. The boom shall project at least 1 m from the vertical pole in the direction of the test sample and shall be arranged so that it can be raised and lowered through a range of heights from 1 m to 4 m. The fixings for the antenna shall permit it to be positioned for measuring the horizontal and vertical components of the electric field. The cable from the antenna shall be mounted along the horizontal boom and vertical pole.
2. For radiation measurements, the test antenna shall be connected to a selective measuring device capable of being tuned to any frequency under investigation. The test sample shall be placed on the test table at a height of 1 m above the plane of the test site.
3. Figure 2 shows the arrangement of conducting radiation measurement using the test antenna.

3.3.3 Substitution antenna

1. The substitution antenna shall be connected to a calibrated signal generator when the site is used for radiation measurement. It shall be a dipole of length equal to half a wavelength for each frequency concerned. The antenna shall be mounted in the way similar to that of test antenna, except that the centre of the antenna shall be located 1 m above the ground plane of the test site.
2. At frequency below about 100 MHz, this is impossible to achieve when the antenna is arranged for vertical polarization. In this case, the lower end of the dipole shall be 0.3 m above the ground.
3. Figure 3 shows the arrangement of conducting radiation measurement using substitution antenna.

3.3.4 Measuring equipment

1. The RF generator, if any, shall be placed at ground level. The selective measuring device may be placed on a suitable table or tripod near the bottom of the support for the test antenna.
2. The measuring instruments or the operator must not be so situated that they have an adverse influence on the measurement by causing reflections or affecting the antenna impedance, particularly when the antenna are at a low height.

3. If the measuring equipment is supplied from the mains, its housing shall be connected to the wire mesh ground screen by a copper braid of minimum length with a width of at least 20 mm.
4. The vertical part of the cable connecting the selective measuring device and the mains supply shall be screened. The rest of the cable, and also the cable connecting the generator and the mains supply, shall be either screened and set at ground level, or shall be buried approximately 300 mm.

4. TESTS

4.1 Output Power of Transmitter

4.1.1 Definition

1. For transmitter operating in the mode of frequency modulation, phase modulation or double sideband amplitude modulation, the output power shall be the measure of carrier power at the output terminals when they are connected to the nominal load condition specified by the manufacturer. The carrier power is the average power during one radio frequency cycle in the absence of modulation.
2. For transmitter operating in the mode of single sideband amplitude modulation, the output power shall be the measure of the peak envelope power at the output terminals when they are connected to the nominal load condition specified by the manufacturer.

4.1.2 Method of measurement for transmitter operating in the mode of frequency modulation, phase modulation or double sideband amplitude modulation

With the equipment set up as shown in figure 4, the carrier power output shall be measured without modulation for a period of 30 minutes using one minute "transmit" and four minutes "standby".

4.1.3 Method of measurement for transmitter operating in the mode of single sideband amplitude modulation

The output power delivered to the artificial load connected to the antenna terminals shall be measured by the method using two modulating oscillations given for single sideband transmitters in CCIR Recommendation 326-5.

4.1.4 Limits

The output power shall not exceed +1.5 dB of the rated output power (see Clause 1.5) under normal test conditions.

4.2 Spurious Emissions of Transmitter

4.2.1 Definition

Spurious emissions are emissions at frequencies other than those of the carrier and sidebands associated with normal modulation resulting from signals generated within the equipment. The level of spurious emissions shall be measured as :-

1. their power level delivered from the transmitter output into a transmission line or antenna; and
2. their effective radiated power when radiated by the cabinet and structure of the equipment which is known as 'cabinet radiation'.

4.2.2 Method of measurement - power level delivered from the output of transmitter operating in the mode of frequency modulation, phase modulation or double sideband amplitude modulation

1. Spurious emissions shall be measured as the power level of any discrete signal delivered into a 50-ohm load. This may be done by connecting the transmitter output through an attenuator to a spectrum analyzer or selective voltmeter, or by monitoring the relative levels of the spurious signals delivered to an artificial load (non-reactive, non-radiating load of 50-ohm). Figure 5 shows the set up.
2. The transmitter shall be operated without any external source of modulation and the measurements made over the frequency range 100 kHz to 1000 MHz or four times the working frequency whichever is the greater, except for the channels on which the transceiver is intended to operate.
3. The measurements shall be repeated with the transmitter modulated with normal test modulation. The measurement shall be repeated with the transmitter in standby for equipment normally arranged for duplex operation.
4. The level of emission shall be measured relative to the carrier emission and the power level shall be determined by applying the ratio measured to the carrier power level.

4.2.3 Method of measurement - power level delivered from the output of transmitter operating in the mode of single sideband amplitude modulation

The transmitter shall be driven to the rated output power by a modulating signal consisting of two audio frequency tones with a frequency separation between them such that all intermodulation products occur at frequencies at least 1500 Hz removed from the assigned frequency. Under these conditions, the power of any unwanted emission, at any discrete frequency, supplied to the artificial load connected to the antenna terminals shall be measured.

4.2.4 Method of measurement - effective radiated power

1. In the measurement of cabinet radiation from a transmitter with antenna output terminals, the transmitter output shall be connected to a non-radiating artificial load.
2. The measurement shall be conducted at a test site and using test equipment conforming to clauses 3.3.1 to 3.3.4.
3. In the case of equipment operating in the mode of frequency modulation, phase modulation or double sideband amplitude modulation, the transmitter shall be tested without any modulation and with normal test modulation.
4. In the case of equipment operating in the mode of single sideband amplitude modulation, the transmitter shall be tested with modulation described in clause 4.2.3.
5. Radiation of any spurious components shall be detected by the test antenna and the selective measuring device over the frequency range 25 MHz to 1000 MHz or 4 times the working frequency, whichever is the greater. At each frequency at which an emission is detected, the sample shall be rotated and the test antenna shall be adjusted in height to obtain maximum response.
6. The sample shall be replaced by a signal generator and dipole antenna (substitution antenna) and the effective radiated power determined by a substitution measurement.
7. The measurements shall be repeated with the test antenna in the orthogonal polarization plane.

4.2.5 Limits

The power of any spurious emission whether measured as output power level at the antenna terminals or effective radiated power in free space in the specified range of frequencies shall not exceed 4 microwatts for amplitude modulation and 0.25 microwatt for frequency modulation and phase modulation.

4.3 Spurious Emission of Receiver

4.3.1 Definition

Spurious emissions from receivers are any emissions present at the antenna terminals of the equipment or radiated from the cabinet and structure of the receiver which is known as 'receiver cabinet radiation'.

4.3.2 Method of measurement - terminal power

With the equipment set up as figure 6 (for equipment with antenna output terminals), the spectrum analyzer shall be tuned slowly and continuously over the frequency range of 100 kHz to 1000 MHz. The level of any spurious emissions observed shall be recorded.

4.3.3 Method of measurement - effective radiated power

For measuring receiver cabinet radiation, the method of measurement shall be as described in Clause 4.2.4 except the test sample is a receiver.

4.3.4 Limits

The power of any spurious emission whether measured as output power level at the antenna terminals or effective radiated power in free space shall not exceed 4 microwatts for amplitude modulation and 20 nanowatts for frequency modulation and phase modulation.

5. ACCURACY OF MEASUREMENT

The tolerance for the measurement of the following parameters shall be as follows :

<u>Measurement</u>	<u>Tolerance</u>
DC voltage	± 3%
AC mains voltage	± 3%
AC mains frequency	± 1 Hz
Audio frequency voltage, power etc	± 0.5 dB
Distortion and noise etc of audio frequency generators	± 1%
Radio frequency	± 100 Hz
Radio frequency voltage	± 2 dB
Radio frequency field strength	± 3 dB
Radio frequency carrier power	± 2 dB
Impedance of artificial loads, combining units, cables, plugs, attenuators etc	± 5%
Source impedance of generators and input impedance of measuring receivers	± 10%

Explanation Notes for Figures 2 and 3

- 1 : test sample
- 2 : selective measuring device
- 3 : centre of test antenna
- 4 : centre of substitution antenna
- 5 : radio frequency signal generator
- 6 : output power meter
- 7 : earth connection and mains supply leads, if any
- 8 : wire mesh ground screen

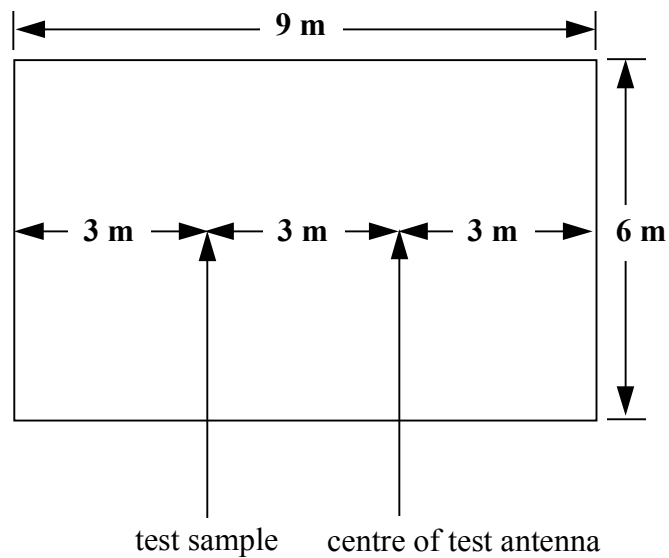

Figure 1 : 3-metre Test Site

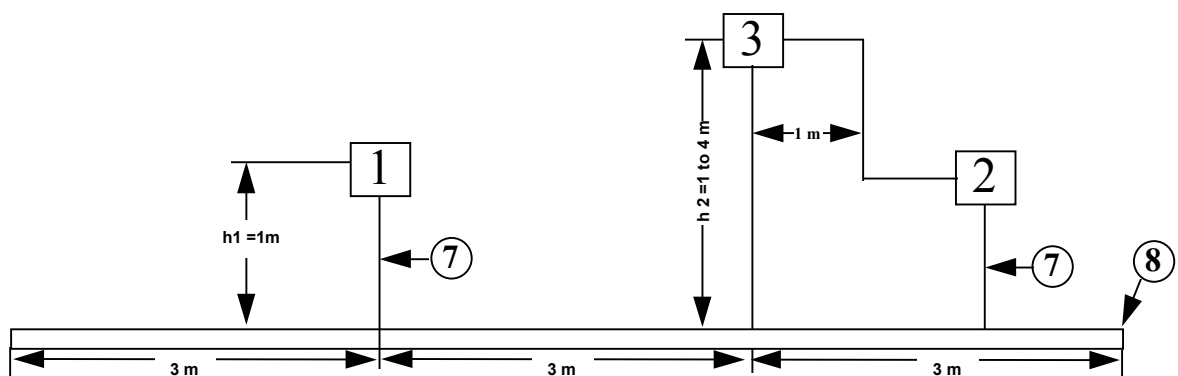

Figure 2 : Radiation Measurement (using Test Antenna)

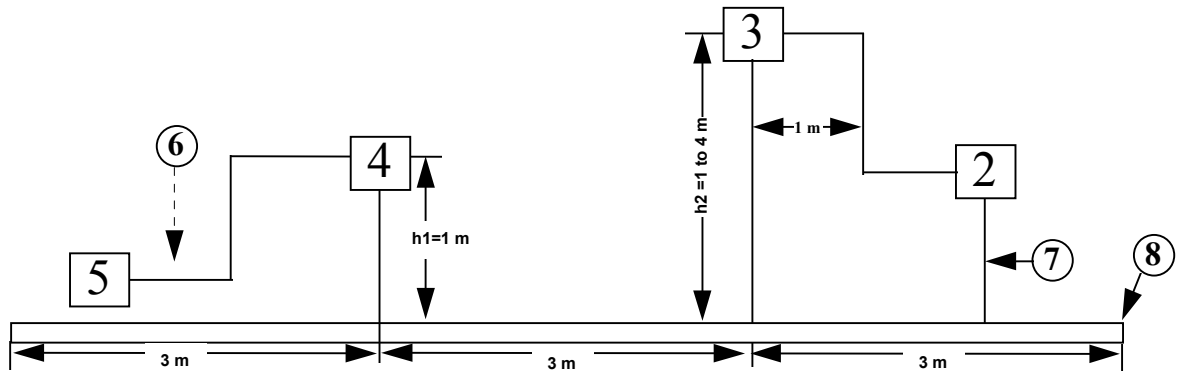

Figure 3 : Radiation Measurement (using Substitution Antenna)

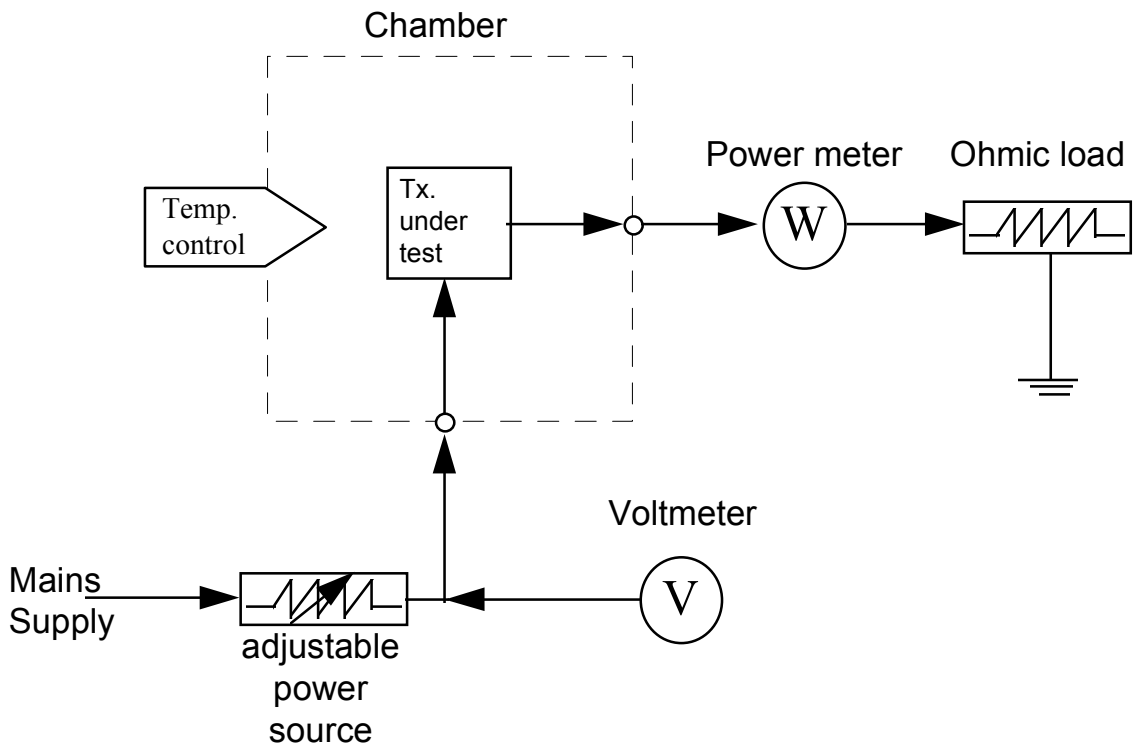

Figure 4 : Carrier Power Test Arrangement

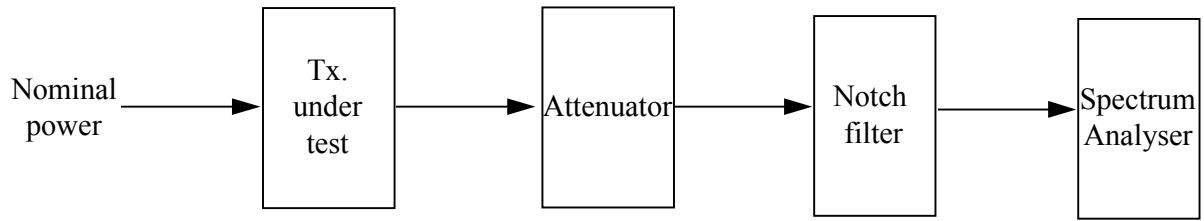

Figure 5 : Spurious Emissions Test Arrangement - Power Level

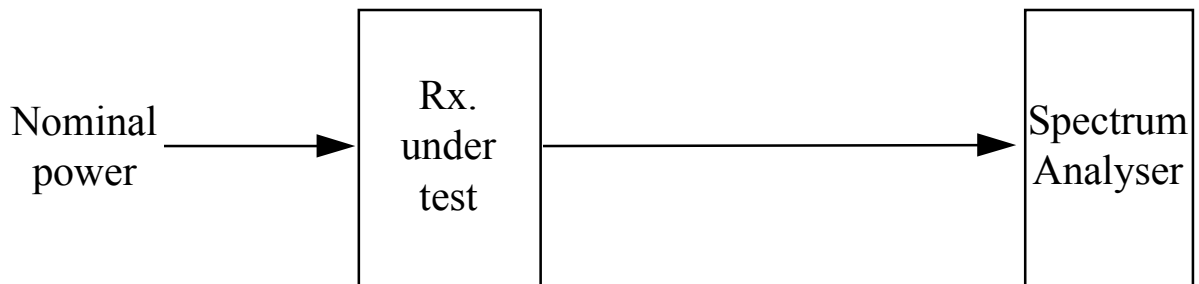

Figure 6 : Receiver Spurious Emissions at Antenna Terminals

Annex 1

Channelling Plan

Channel No.	Frequency Range (MHz)	Carrier Frequency (MHz)
1	26.960 - 26.970	26.965
2	26.970 - 26.980	26.975
3	26.980 - 26.990	26.985
4	27.000 - 27.010	27.005
5	27.010 - 27.020	27.015
6	27.020 - 27.030	27.025
7	27.030 - 27.040	27.035
8	27.050 - 27.060	27.055
9	27.060 - 27.070	27.065
10	27.070 - 27.080	27.075
11	27.080 - 27.090	27.085
12	27.100 - 27.110	27.105
13	27.110 - 27.120	27.115
14	27.120 - 27.130	27.125
15	27.130 - 27.140	27.135
16	27.150 - 27.160	27.155
17	27.160 - 27.170	27.165
18	27.170 - 27.180	27.175
19	27.180 - 27.190	27.185
20	27.200 - 27.210	27.205
21	27.210 - 27.220	27.215
22	27.220 - 27.230	27.225
23	27.250 - 27.260	27.255
24	27.230 - 27.240	27.235
25	27.240 - 27.250	27.245
26	27.260 - 27.270	27.265
27	27.270 - 27.280	27.275
28	27.280 - 27.290	27.285
29	27.290 - 27.300	27.295
30	27.300 - 27.310	27.305
31	27.310 - 27.320	27.315
32	27.320 - 27.330	27.325
33	27.330 - 27.340	27.335
34	27.340 - 27.350	27.345
35	27.350 - 27.360	27.355
36	27.360 - 27.370	27.365
37	27.370 - 27.380	27.375
38	27.380 - 27.390	27.385
39	27.390 - 27.400	27.395
40	27.400 - 27.410	27.405