

HKTA 2005
ISSUE 05
FEBRUARY 2003

**NETWORK CONNECTION SPECIFICATION
FOR CONNECTION OF
50-BAUD OR 300-BAUD SUBSCRIBER
TELEX EQUIPMENT
TO THE PUBLIC TELEX NETWORK
IN HONG KONG**



TELECOMMUNICATIONS AUTHORITY
HONG KONG

FOREWORD

1. This specification is issued pursuant to Section 32D of the Telecommunications Ordinance (Cap. 106). This specification sets out the technical requirements for connection of a 50-baud or 300-baud subscriber telex equipment to the public telex network in Hong Kong.
2. At present, the Office of the Telecommunications Authority (OFTA) operates a **Hong Kong Telecommunications Equipment Evaluation and Certification (“HKTEC”)** scheme. Details of the scheme can be found in the information note OFTA I 421. Under the scheme, suppliers or manufacturers may apply to OFTA for certification of their customer premises equipment against this specification. The application procedures for certification of customer premises equipment can be found in the information note OFTA I 412. A prescribed label may be affixed to the equipment which has been certified by the Telecommunications Authority (TA). Details of the labelling arrangement can be found in the Standardisation Guide HKTA 3211.
3. The TA may amend any part of this specification as and when he deems necessary.
4. In case of doubt about the interpretation of this specification, the methods of carrying out the test and the validity of statements made by the manufacturers of the equipment, the decision of the TA shall be final.
5. The TA accepts no responsibility for the satisfactory performance of the CPE connected to the public telecommunications networks. The CPE is not normally evaluated against performance, reliability or quality-of-service parameters.
6. The HKTA specifications and information notes issued by the TA can be obtained through one of the following methods:-
 - Downloading direct through the OFTA’s Internet Home Page. The Home Page address is <http://www.ofta.gov.hk>;
 - Making a request for hard copies to:-

Senior Telecommunications Engineer
Standards Section
Office of the Telecommunications Authority
29/F Wu Chung House
213 Queen’s Road East
Wanchai
Hong Kong

Fax: +852 2838 5004
Email: standards@ofta.gov.hk

7. Enquiries about this specification may be directed to:-

Senior Telecommunications Engineer
Standards Section
Office of the Telecommunications Authority
29/F Wu Chung House
213 Queen's Road East
Wanchai
Hong Kong

Fax: +852 2838 5004
Email: standards@ofta.gov.hk

AMENDMENT TABLE

Item	Issue No.	Paragraph	Descriptions
1.	Issue 5	Foreword	Add information on HKTEC Scheme. Certification and labelling arrangements are updated.
2.	Issue 5	1.2	The specifications quoted in (b) and (c) are deleted as the requirements are included in the HKTA 2001.

CONTENTS

1. SCOPE
 - 1.1 General
 - 1.2 Safety and electrical protection
2. LIST OF ABBREVIATIONS & SYMBOLS
3. COMMUNICATION INTERFACE
 - 3.1 Introduction
 - 3.2 V.F. interface
 - 3.3 D.C. interface
 - 3.4 External modem
4. SIGNAL CHARACTERISTICS
 - 4.1 Free state
 - 4.2 Outgoing call from a terminal to the ATX
 - 4.3 Incoming call to a terminal from the ATX
5. CALL CONTROL AND SERVICE SIGNALS
 - 5.1 Telex control formats
6. TERMINAL REQUIREMENTS FOR 50-BAUD TELEX
 - 6.1 Coding
 - 6.2 Modulation rate
 - 6.3 Transmission characteristics
 - 6.4 Characters per line
 - 6.5 Printing of line signals
 - 6.6 Answerback
 - 6.7 Selection
 - 6.8 Call collision
 - 6.9 Automatic retry
 - 6.10 Message transmission
 - 6.11 Incoming call
 - 6.12 Clearing an established call
 - 6.13 Terminal parameters

7. TERMINAL REQUIREMENTS FOR 300-BAUD TELEX

- 7.1 Coding
- 7.2 Synchronisation
- 7.3 Characters per line
- 7.4 Printing of line signals
- 7.5 Answerback
- 7.6 Selection
- 7.7 Call collision

- 7.8 Automatic retry
- 7.9 Message transmission
- 7.10 X-off / X-on flow control
- 7.11 Incoming call
- 7.12 Clearing an established call
- 7.13 Terminal parameters

8. TELECOMMUNICATION SYSTEMS

APPENDIX A

1 SCOPE

1.1 General

1.1.1 This specification details the requirements of a 50-baud or 300-baud telex subscriber terminal that is to be connected to the Public Telex Network in Hong Kong.

1.1.2 For connection of computers, word processors or any other terminals to the telex network, using either an integral or standalone interface, shall meet the requirements of this specification.

1.2 Safety And Electrical Protection

In order to safeguard operating personnel, users, and plant, it is essential to prevent the transmission of excessive voltages from the telex subscriber equipment into the public telecommunication network in Hong Kong. The equipment shall comply with the latest edition of the following specification :-

- HKTA 2001 “Safety and Electrical Protection Requirements for Subscriber Equipment connected to the Public Telecommunication Networks in Hong Kong” issued by the Telecommunications Authority,

2 LIST OF ABBREVIATIONS & SYMBOLS

In general, ITU-T terminology is adopted.

ITU-T	Telecommunication Standardisation Sector of International Telecommunication Union (ITU)
ATX	Automatic telex exchange
ACK	Acknowledge signal
CR	Carriage return
ENQ	Enquiry
LS	Letter shift
LF	Line feed
FS	Figure shift
SP	Space
'A'	'Space' polarity or 'start' condition of a telegraph signal
'Z'	'Mark' polarity or 'stop' condition of a telegraph signal
F _A	Space frequency
F _Z	Mark frequency
AAD	Automatic advice of duration
CI	Conversation impossible
NP	The called party is not or is no longer a subscriber
OCC	Occupied
PTS	Proceed to select
RDI	Call re-direction
TOD	Time of delivery
WRU	Who-are-you signal

3 COMMUNICATION INTERFACE

3.1 Introduction

A subscriber terminal will normally communicate with the ATX over a pair of wires rented from the public telecommunication network operator using frequency shift keying of voice frequencies. If a terminal has a built-in modem, the modem shall have the characteristics as stipulated in Section 3.2 and it shall conform to the requirements of the public telecommunication network operator. Where a terminal does not have a built-in modem, a telegraph modem can be rented from the telex network operator or supplied separately; however, the interface signalling shall in this case have the characteristics as stipulated in Section 3.3.

3.2 V.F. Interface

The built-in modem of a terminal, if provided, shall conform to ITU-T Recommendation R.20 (Telegraph modem for subscriber lines).

3.2.1 Channel Allocation

The modem shall be set to receive channel 1 frequencies and transmit channel 2 frequencies as per the following table.

Terminal or line condition	RECEIVE		TRANSMIT	
	MARK	SPACE	MARK	SPACE
Frequency	980 Hz	1180 Hz	1650 Hz	1850 Hz
Nominal mean	1080 Hz		1750 Hz	

The characteristic frequencies as measured at the telegraph modem line output shall not differ by more than ± 3 Hz. The modem shall continue to operate with a ± 6 Hz change in receive frequency.

3.2.2 Transmit Level

When terminated by a 600 ohms load, the nominal output level to line shall be -10 dBm ± 1 dB. The difference in output levels between F_A and F_Z shall be not greater than 1dB.

3.2.3 Receive Level Sensitivity

When the received signal level is -43 dBm or greater, the modem shall correctly interpret the line condition as either F_A or F_z .

When the received signal level falls to -48 dBm or less, the modem shall interpret the line condition as F_A .

When the received signal level falls within the range -43 dBm to -48 dBm, the modem shall either correctly interpret the line condition (clamp off) or interpret the line condition as F_A . (clamp on) . However, there shall be a hysteresis such that the level at which the off-to-on transition occurs shall be greater than 2 dB above the level at which on-to-off transition occurs.

3.2.4 Impedance

The line interface of the modem shall be balanced and shall present an impedance of 600 ohms with a return loss of not less than 14 dB at any frequencies quoted in Section 3.2.1.

3.3 D.C. Interface

A terminal without built-in modem may interface to the telex network via a telegraph modem. In this case, the terminal interface shall conform to the ITU-T Recommendation V.28 and the modem shall conform to the V.F. specifications of paragraph 3.2.

The following interchange circuits shall be used

Common return	(Circuit 102 in ITU-T Rec. V.24)
Transmitted data	(Circuit 103 in ITU-T Rec. V.24)
Received data	(Circuit 104 in ITU-T Rec. V.24)
Carrier detect	(Circuit 109 in ITU-T Rec. V.24)

3.4 External Modem

If a modem is supplied separately, it shall transmit the F_A frequency when the terminal is not connected to the modem.

4 SIGNAL CHARACTERISTICS

A 50-baud or a 300-baud telex terminal shall conform to the timing requirements as shown in Figure 1 and 2. These figures show the relationship between a telex terminal and the ATX in a normal telex call.

4.1 Free State

The free state is steady 'A' (space) condition bothways. A telex terminal shall not generate any spurious signal at free line state.

4.2 Outgoing Call from A Terminal to the ATX

4.2.1 Call Initiation

To indicate a call, the terminal shall transmit a steady 'Z' (mark) condition. Call confirmation is returned by the ATX with a delay of not more than 200 milliseconds after receipt of the calling signal.

Note : The terminal shall be able to detect the PTS sequence in order to detect a call collision condition.

4.2.2 Proceed-To-Select

When the ATX is ready to receive the selection information, the PTS sequence will be transmitted. The maximum delay between the call confirmation and the PTS signals shall be less than 15 seconds.

The absence of the PTS signal will serve to detect a call collision condition. In such case, the terminal shall accept the incoming call and the outgoing call shall be aborted or retried at a later stage.

4.2.3 Transmission of Selection

The terminal shall transmit the digits of the required number followed immediately by the end-of-select character (+) within 10 seconds after reception of the PTS. The maximum allowed delay between successive characters is 10 seconds. If this time is exceeded, the ATX will send the service signal NP to the calling terminal followed by a steady 'A' condition.

Following the selection, there may be a delay of up to 2 minutes before the ATX gives any response during which time the terminal must maintain a steady 'Z' condition on the line.

4.2.4 Connection Establishment

After transmission of the selection sequence, the terminal shall receive the service identification signal or the answerback code of the called party to indicate that the connection has been established.

If the ATX is unable to establish a connection for any reason, a service signal will be sent to the terminal followed immediately by a steady 'A' condition.

4.2.5 Message Transmission

After establishing the connection to the called party, message transmission from the terminal can commence.

4.2.6 Cleardown

At the end of a call, the terminal releases the line by reverting to a steady 'A' condition. At this time the terminal shall remain active to receive the Automatic Advice of Duration (AAD) from the ATX until the clear confirmation is detected.

If the call is cleared by the called party, the ATX will send the AAD and revert to 'A' condition. The terminal shall interpret an 'A' condition of longer than 300 milliseconds as clear condition and it shall send a clear confirmation by reverting to 'A' condition. If the ATX does not receive the clear confirmation within 5 minutes, the ATX will mark the line as out of order.

4.3 Incoming Call to A Terminal from the ATX

4.3.1 Call Reception

An incoming call is characterised by the inversion of incoming line signal from 'A' (space) to 'Z' (mark) condition. The terminal shall generate a call confirmation of steady 'Z' condition on the outgoing line as soon as possible. In any event, the delay shall not exceed 6 seconds.

4.3.2 Terminal Identification

The ATX will send the WRU signal to the telex terminal at 2 to 4.2 seconds after call confirmation is received. A 50-baud terminal shall respond by sending its answerback code sequence within 0.6 second. A 300-baud terminal shall response within 0.15 second.

An automatic terminal may return a WRU signal to the calling party, 800 milliseconds after the return of its answerback code sequence, provided that the incoming path to the terminal remains idle. The terminal must not return the WRU signal once the text transmission from the calling party has commenced.

4.3.3 Message Reception

The terminal shall expect to receive message characters after generating the answerback and shall maintain steady 'Z' condition on the outgoing line. Any occurrence of a WRU signal (50 bauds) or an ENQ signal (300 bauds) in the message shall be recognised by the terminal and the answerback sequence transmitted again.

4.3.4 Cleardown

If the call is cleared by the calling terminal, ATX will revert to an 'A' condition after sending TOD. The terminal will interpret an 'A' condition of longer than 300 milliseconds as clear condition and send out a clear confirmation by reverting to an 'A' condition. If the ATX does not receive the clear confirmation within 5 minutes, it will mark the line as out of order.

If the call is cleared by the called terminal, the terminal shall revert to an 'A' condition and remains active to receive the TOD from the ATX. On reception of the clear signal, the ATX sends TOD and then reverts to 'A' condition.

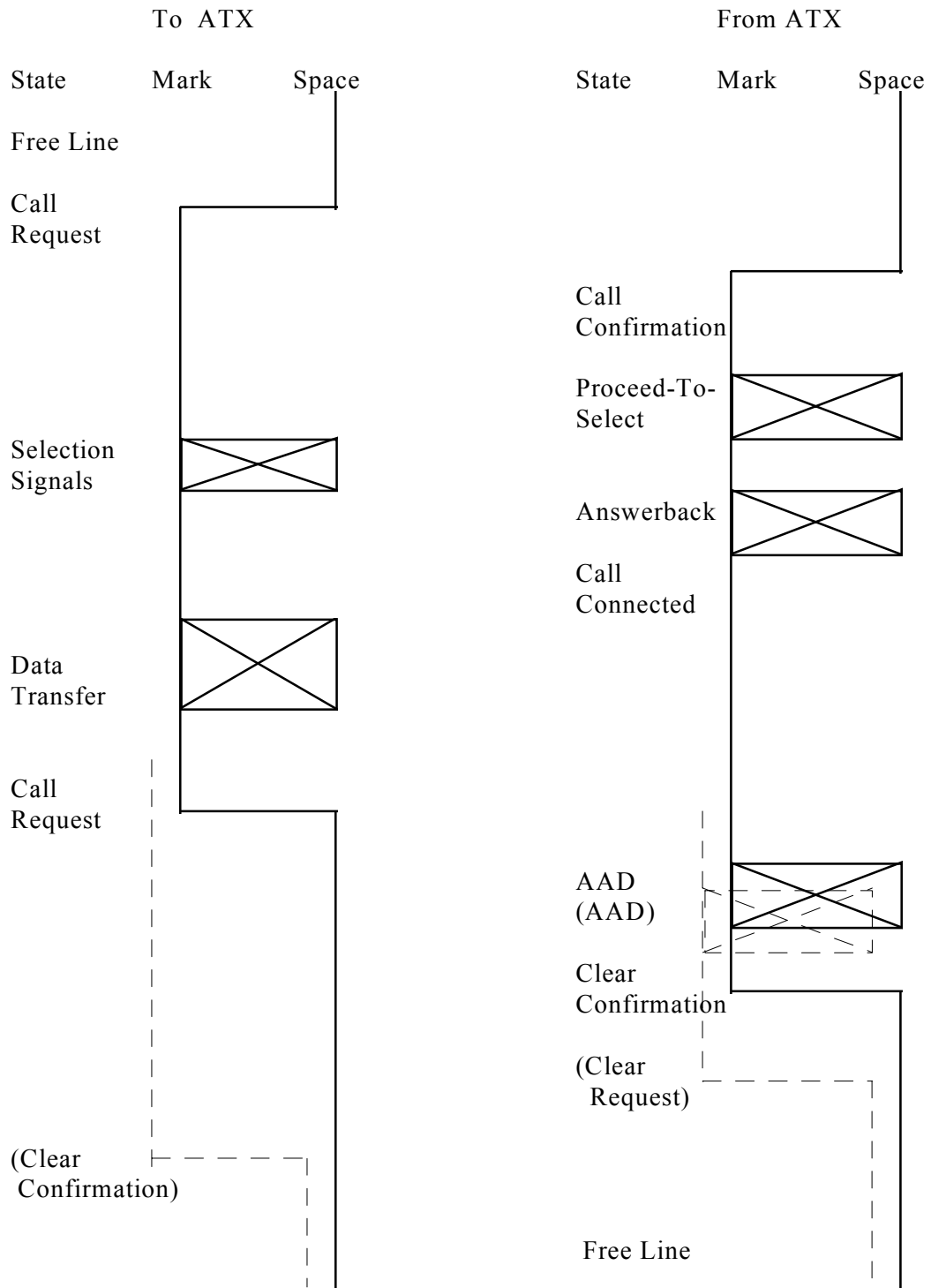

Figure 1 Timing requirement of a 50-baud or 300-baud telex terminal for outgoing call from the terminal.

Note : After the data transfer stage, the dotted line and words inside a bracket indicate the call is cleared by ATX while the solid line indicates the call is cleared by the terminal.

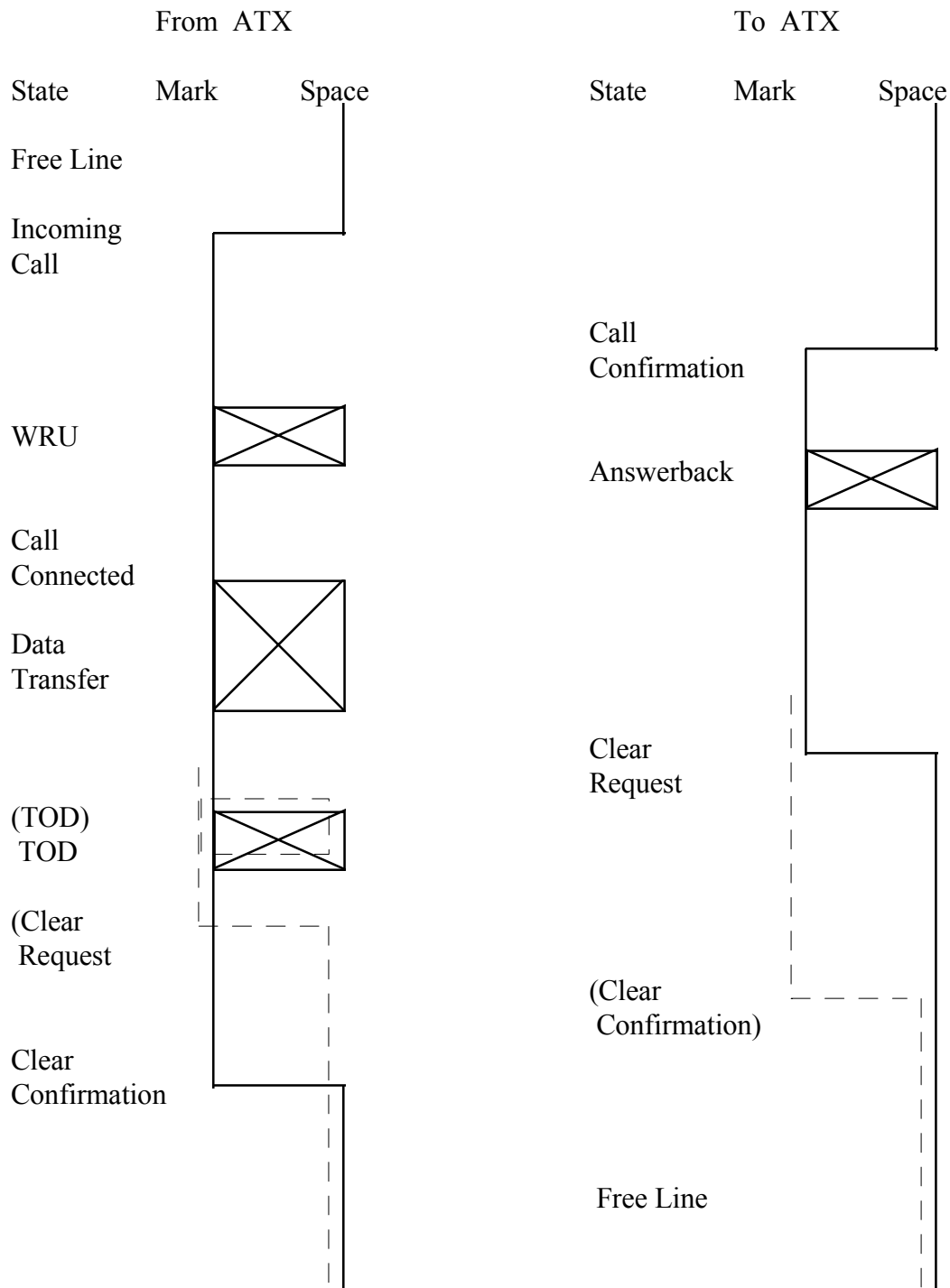

Figure 2 Timing requirement of a 50-baud or 300-baud telex terminal for incoming call to the terminal.

Note: After the data transfer stage, the dotted line and words inside a bracket indicate that call is cleared by ATX while the solid line indicates the cell is cleared by the terminal.

5 CALL CONTROL AND SERVICE SIGNALS

A terminal to be used in the Telex Network shall be able to send or receive without errors on the telex call control and service signals as stipulated below.

5.1 Telex Control Formats

All characters for call control purposes are selected from International Telegraph Alphabet No. 2 (ITA2 for 50 bauds) and International Alphabet No. 5 (IA5 for 300 bauds) according to the ITU-T recommendation. Even parity applies for IA5 in all characters interchanged for call control purposes.

5.1.1 PTS : Proceed-to-select

CR LF FS DDHHMM SP LS P T S CR LF (50 bauds format)
CR LF DDHHMM SP P T S CR LF ACK (300 bauds format)

where DD : Day
HH : Hour
MM : Minute
for example :- 120456 PTS

5.1.2 Selection :

a. Selection for local number

FS NNNNN+ (50 bauds format)
NNNNN+ (300 bauds format)

where N : a numeral 0 to 9
for example : - 79876+

b. Selection for international number

FS ODDDNN ... N (50 bauds format)
ODDDNN... N+ (300 bauds format)
where 0 : International call indication
DDD : ITU-T Rec.F.69 telex destination code
N : numeral 0 to 9
for example : - 08754321+

5.1.3 WRU : Who-are-you (WRU) signal

FS D This signal shall be used exclusively for operating the answerback unit of the 50-baud telex terminal.

ACK SP ENQ This signal shall be used exclusively for operating the answerback unit of the 300-baud telex terminal and will be transmitted after the first answerback of :-

ENQUIRY, INTERSPEED, STARTEX AND SYNDICATE service positions.

5.1.4 Service Signals

The 50-baud terminal shall be able to receive the following service signals followed by ATX cleardown for ineffective calls.

CR LF LS A B S CR LF Absent subscriber/office closed

CR LF LS D E R CR LF Out of order

CR LF LS I N F CR LF Subscriber temporarily unobtainable, call the information service

CR LF LS N A CR LF Connection not allowed

CR LF LS N C CR LF No circuit available

CR LF LS N C H CR LF Subscriber's number has been changed

CR LF LS N P CR LF Number does not exist

CR LF LS 0 C C CR LF Subscriber is engaged

Note: There will be no LS (Letter shift) in the above service signals in 300 bauds operation.

5.1.5 Call Redirection

The terminal shall be able to receive and respond properly to the following call redirection service code :-

CR LF S R D I FS : SP X ... X + CR LF (50 bauds format)

CR LF R D I : SP X ... X + CR LF (300 bauds format)

Where X...X : the new number

for example :- RDI : 79876+

Where a call redirection facility is in force, the ATX will respond as above and then attempt to connect to the new number. The terminal shall, after receiving the RDI code, wait until the answerback (or the service signal) is received.

5.1.6. AAD : Automatic advice of duration

The AAD is sent by the ATX at the end of a real time connected outgoing telex call. When the call is cleared down, the terminal shall remain active until the AAD is received. The AAD format is:

```
CR LF LS A A D SP FS MMM.X CR LF      (50 bauds format)
CR LF A A D SP MMM.X CR LF             (300 bauds format)
```

where MMM : Minutes
X : Tenths of a minute rounded up to the next charging unit
for example :- AAD 001.2

5.1.7 TOD : Time of delivery

The TOD is sent by the ATX at the end of an incoming call after the call is cleared by the calling party. If the called terminal clears down before the calling party, it shall remain active until TOD is received. The TOD format is

```
CR LF LS T 0 D SP FS DDHHMM CR LF      (50 bauds format)
CR LF T 0 D SP DDHHMM CR LF            (300 bauds format)
```

where DD : Day
HH : Hour
MM : Minute
for example:- TOD 010233

5.1.8 Interspeed

When a call is made from a 300-baud telex terminal to a 50.-baud subscriber, it is automatically routed to a 'store and forward' message handling system. The answerback of the INTERSPEED is :-

```
CR LF I N T E R S P E E D SP H
```

for example : INTERSPEED HX

A reference number will be given for identification and reference (at the end of the call). The format of the reference number is :-

```
"ITD SP #nnnnnn"
```

where ITD : is the abbreviation of input transaction accepted for delivery
: may be a letter M or H
nnnnnn : the reference number
for example : - ITD M123456

6 TERMINAL REQUIREMENTS FOR 50-BAUD TELEX

6.1 Coding

The ITU-T ITA No.2 shall be used for telex communication. The ITA No.2 is a 5-unit coded character set as defined in the ITU-T Recommendation S.1.

6.2 Modulation Rate

The terminal shall have a start/stop transmission cycle with a mean modulation rate of 50 bauds at $\pm 0.1\%$. The nominal duration of the transmitting cycle shall be at least 7.4 units, the stop element lasting for at least 1.4 units. The receiver must be able to translate correctly in service the signals coming from a source that appears to have a nominal transmit cycle equal to or greater than 7.25 units.

6.3 Transmission Characteristics

The degree of gross start-stop distortion of transmitted signals, measured at the output of the terminal-must not exceed 10% or 5% at the D.C. interface if an integral modem is not incorporated.

6.4 Characters Per Line

The maximum number of characters per line is fixed at 69. The terminal shall be capable of receiving 69 printing or spacing characters without local introduction of a new line sequence.

6.5 Printing of Line Signals

Any terminal with or without video display unit shall include a printer that records at least all signals sent or received on the line. The format of the printed message shall be in exact form in which it was transmitted or received.

6.6 Answerback

The telex terminal shall send the answerback sequence automatically upon reception of the WRU signal from the line. A WRU signal generated by the terminal shall not cause the generation of its own answerback sequence.

The delay between the reception of the beginning of the start unit of control character WRU and the beginning of the start unit of the first signal of the answerback sent by the terminal shall be between one and four character periods.

The answerback sequence shall be composed of 20 characters. It shall include the subscriber's local call number, name designating the subscriber and network identification code preceded by a space.

Where an answerback is stored electronically it must not be stored in volatile memory nor shall it be capable of being changed by the terminal operator.

The answerback sequence must be registered with the telex network operator and shall not be altered in any way without prior reference to them.

The following order of the characters shall be used :

- 1 letter-shift or figure shift;
- 1 carriage-return;
- 1 line-feed;
- 16 characters which consists of :-

FS NNNNN SP LS A ... A SP HX

where NNNNN is the telex number,

SP is the space code,

A ... A consists of 3 to 5 letters designating subscriber name,

HX is the network code for Hong Kong

1 letter-shift.

For example :- 79876 ABCCO HX

Note: When the code signal does not comprise 16 characters, the unused places shall be filled by the necessary number of letter shifts, which shall preferably be inserted before the network code.

Where a unit has multiple line terminations with associated answerbacks it is essential that the line number/answerback relationship does not change.

If a reperforator unit is incorporated in the terminal, it shall not perforate the WRU signal.

6.7 Selection

Automatic machines shall start to send selection characters within 10 seconds after receipt of the PTS signal.

When no PTS nor any other signal is received within 90 seconds from the commencement of the call request from the terminal, the terminal shall revert to the free line condition.

Not more than 3 reattempts shall be made. Each call attempt must not be made within a minimum period of 20 seconds.

If the terminal is unable to establish a call at the last attempt, the call attempt shall be abandoned and an appropriate fault report given.

6.8 Call Collision

When a call collision condition is detected, the terminal shall accept the incoming call and the outgoing call shall be aborted or retried at a later stage.

6.9 Automatic Retry

Terminals which are equipped with automatic retry facilities for ineffective calls shall comply with the ITU-T Recommendation U.40 and shall have transmission status report available to the user.

6.10 Message Transmission

At any time during the automatic transmission, the detection of incoming signals, or transmission failure, will cause an alarm to be raised. Automatic transmission will also be stopped. If the incoming signals are not sustained, but consist of only an isolated pulse exceeding 10 milliseconds or a single spurious character, the automatic transmission may be resumed after a maximum delay of 1 second. If more than two interruptions are detected, the transmission of the message shall be abandoned.

In no case shall a multiple-line terminal equipment be allowed to present the same call simultaneously on more than one telex line.

6.11 Incoming Call

When a terminal is working 'in local', priority shall be given to incoming calls.

Where a terminal is incapable of a conversational mode of operation, either through the absence of a keyboard or for local operational reasons, then the terminal shall be able to automatically return an appropriate service signal sequence on receipt of one or more BELL characters. The ITU-T recommended sequence of signal to be returned is : CI (conversation impossible)

When a terminal is arranged to avoid interruption to local message preparation, it shall correctly respond to the incoming call (WRU etc.) as specified in Section 4.2. It may store and/or print out the incoming message without interrupting local working and shall indicate by means of a suitable alarm that there is an incoming message awaiting attention. The incoming message recorded in the store must be printed as soon as the printer is available.

A terminal shall not accept any incoming call when a paper out condition occurs.

If a terminal is provided with storage facilities and a paper low or paper out condition occurs it may continue to receive calls but shall disconnect the connection when or before store reaches the full condition.

6.12 Clearing An Established Call

A permanent clear signal (F_A) shall be sent from the terminal when it is required to clear from the terminal.

The terminal shall remain active to receive all answerbacks and/or service signals after a clear signal is initiated.

6.13 Terminal Parameters

All terminal parameters as listed in this Section must be protected from being changed by the subscriber.

7 TERMINAL REQUIREMENTS FOR 300-BAUD TELEX

7.1 Coding

The ITU-T IA No.5 shall be used for telex communication. The IA No.5 is a 7-unit coded character set as defined in the ITU-T Recommendation T.50. Even parity according to the ITU-T Recommendation X.4 shall be applied for characters interchanged between the terminal and the ATX for call control purposes.

7.2 Synchronisation

The terminal shall have a start/stop transmission cycle with a mean modulation rate of 300 bauds at $\pm 0.1\%$. The nominal duration of the transmitting cycle shall be at least 10 units, the stop element lasting for at least 1 unit. The receiver must be able to translate correctly in service the signals coming from a source that appears to give stop elements equal to or greater than 0.8 unit.

7.3 Characters Per Line

The maximum number of characters per line for 300 bauds operation is 80. The terminal shall be capable of receiving 80 printing or spacing characters without local introduction of a new line sequence. However, the terminal shall provide optional selection of the maximum number of characters per line to be set at 69 in order to communicate with a 50-baud telex without causing garble printing at end of a line.

7.4 Printing of Line Signals

Any terminal with or without video display unit, or message memory storage shall have a permanent record at least on all signals sent or received on the line.

7.5 Answerback

The telex terminal shall send the answerback sequence automatically upon reception of the ENQ signal from the line. An ENQ signal generated by the terminal shall not cause the generation of its own answerback sequence.

The delay between the reception of the beginning of the start unit of control character ENQ and the beginning of the start unit of the first signal of the answerback sent by the terminal shall be between one and four character periods.

The answerback sequence shall be composed of 20 characters. It shall include the subscriber's local call number, name designating the subscriber and network identification code preceded by a space.

Where an answerback is stored electronically it must not be stored in volatile memory nor shall it be capable of being changed by the terminal operator.

The answerback sequence must be registered with the telex network operator and shall not be altered in any way without prior reference to them.

The following order of the characters shall be used :

- 1 SI (position 0/15 in the code table as given in Appendix A),
- 1 CR (position 0/13 in the code table as given in Appendix A),
- 1 LF (position 0/10 in the code table as given in Appendix A),
- 1 SO (position 0/14 in the code table as given in Appendix A),
- 14 characters which consists of :-

NNNNN SP A ... A SP HX

where NNNNN is the telex number,
SP is the space code (position 2/00 in the code table),
A ... A consists of 3 to 5 letters designating subscriber name,
HX is the network code for Hong Kong.

Note: When the code signal does not comprise 14 characters, signals (such as -NUL) must be inserted at unused places and before the network code. The combination of characters shall exclude all control characters such as ENQ, CR or LF.

2 non-printing, non-carriage moving signals, such as DEL or NUL.
For example :- 79876 ABCCO HX

Where a unit has multiple line terminations with associated answerbacks it is essential that the line number/answerback relationship does not change.

7.6 Selection

Automatic machines shall start to send selection characters within 10 seconds after receipt of the PTS signal.

When no PTS nor any other signal is received within 90 seconds from the commencement of the call request from the terminal, the terminal shall revert to the free line condition.

Not more than 3 reattempts shall be made. Each call attempt must not be made within a minimum period of 20 seconds.

If the terminal is unable to establish a call at the last attempt, the call attempt shall be abandoned and an appropriate fault report given.

7.7 Call Collision

When a call collision condition is detected, the terminal shall accept the incoming call and the outgoing call shall be aborted or retried at a later stage.

7.8 Automatic Retry

Terminals which are equipped with automatic retry facilities for ineffective calls shall comply with the ITU-T Recommendation U.40 and shall have transmission status report available to the user.

7.9 Message Transmission

At any time during the automatic transmission the detection of incoming signals, or transmission failure, will cause an alarm to be raised. Automatic transmission will also be stopped. If the incoming signals are not sustained, but consist of only an isolated pulse exceeding 1.7 milliseconds or a single spurious character, the automatic transmission may be resumed after a maximum delay of 1 second. If more than two interruptions are detected the transmission of the message shall be abandoned.

In no case shall a multiple-line terminal equipment be allowed to present the same call simultaneously on more than one telex line.

7.10 X-Off / X-On Flow Control

The terminal shall be capable to perform the x-off/x-on flow control during data transmission or reception. The terminal shall immediately stop data transmission upon receiving a device control character of DC3 and shall resume its data transmission upon receiving a device control character of DC1.

7.11 Incoming Call

When a terminal is working in local', priority shall be given to incoming calls.

Where a terminal is incapable of a conversational mode of operation, either through the absence of a keyboard or for local operational reasons, then the terminal shall be able to automatically return an appropriate service signal sequence on receipt of one or more BELL characters. The ITU-T recommended sequence of signal to be returned is: CI (conversation impossible)

When a terminal is arranged to avoid interruption to local message preparation, it shall correctly respond to the incoming call (WRU etc.) as specified in Section 4.2. It may store and/or print out the incoming message without interrupting local working and shall indicate by means of a suitable alarm that there is an incoming message awaiting attention. The incoming message recorded in the store must be printed as soon as the printer is available.

A terminal shall not accept any incoming call when a paper out condition occurs.

If a terminal is provided with storage facilities and a paper low or paper out condition occurs it may continue to receive calls but shall disconnect the connection when or before store reaches the full condition.

7.12 Clearing An Established Call

A permanent clear signal (F_A) shall be sent from the terminal when it is required to clear from the terminal.

The terminal shall remain active to receive all answerbacks and/or service signals after a clear signal is initiated.

7.13 Terminal Parameters

All terminal parameters as listed in this Section must be protected from being changed by the subscriber.

8. TELECOMMUNICATION SYSTEMS

Where automatic systems are connected to the telex network through interface devices, the automatic systems shall comply with the relevant parts of this specification. For example, the control of automatic retry shall comply with ITU-T Recommendation U.40.

In addition, the automatic systems shall comply with the relevant parts of the ITU-T Recommendation where applicable. For example, to comply with the ITU-T Recommendation S.23 if the system is equipped with the automatic request of the calling party answerback.

Appendix A

International Alphabet No. 5 Code Table

	0	1	2	3	4	5	6	7
0	NUL	DLE	SP	0	@	P	`	P
1	SOH	DC ₁	!	1	A	Q	a	q
2	STX	DC ₂	"	2	B	R	b	r
3	ETX	DC ₃	#	3	C	S	c	s
4	EOT	DC ₄	⊠	4	D	T	d	t
5	ENQ	NAK	%	5	E	U	e	u
6	ACK	SYN	&	6	F	V	f	v
7	BEL	ETB	'	7	G	W	g	w
8	BS	CAN	(8	H	X	h	x
9	HT	EM)	9	I	Y	i	y
10	LF	SUB	*	:	J	Z	j	z
11	VT	ESC	+	;	K	[k	{
12	FF	IS ₄	,	<	L	\	l	
13	CR	IS ₃	-	=	M]	m	}
14	SO	IS ₂	.	>	N	^	n	-
15	SI	IS ₁	/	?	O	-	o	DEL

Note : The ⊠ sign is the currency sign which can be \$