

HKTA 2013
ISSUE 4
MAY 2010

**NETWORK CONNECTION SPECIFICATION
FOR CONNECTION OF CUSTOMER
PREMISES EQUIPMENT (CPE) TO
DIRECT-DIAL-IN (DDI) LINE OF
THE PUBLIC SWITCHED TELEPHONE
NETWORK (PSTN) IN HONG KONG**



**TELECOMMUNICATIONS AUTHORITY
HONG KONG**

FOREWORD

1. This specification is issued pursuant to Section 32D of the Telecommunications Ordinance (Cap. 106). This specification sets out the technical requirements for connection of multi-line customer premises equipment (CPE) to the direct-dial-in (DDI) lines of the Public Switched Telephone Network (PSTN) in Hong Kong.
2. DDI lines may be provided by any one of the Fixed Telecommunications Network Services (FTNS) operators in Hong Kong. CPE should comply with this specification for connection to the DDI lines provided by the FTNS operators. The general technical characteristics of the FTNS networks are given in HKTA 2201. Supplementary information on network characteristics and services of the FTNS networks may be obtained direct from the operators. Contact information of the FTNS operators can be found in the information note OFTA I 412.
3. At present, the Office of the Telecommunications Authority (OFTA) operates a **Hong Kong Telecommunications Equipment Evaluation and Certification** (“HKTEC”) scheme. Details of the scheme can be found in the information note OFTA I 421. Under the scheme, suppliers or manufacturers may apply for certification of their customer premises equipment against this specification. The application procedures for certification of customer premises equipment can be found in the information note OFTA I 412. A label prescribed by the Telecommunications Authority (TA) may be affixed to the certified equipment. Details of the labelling arrangement can be found in the Standardisation Guide HKTA 3211.
4. The TA may amend any part of this specification as and when he deems necessary.
5. In case of doubt about the interpretation of this specification, the methods of carrying out the test and the validity of statements made by the manufacturers of the equipment, the decision of the TA shall be final.
6. The TA accepts no responsibility for the satisfactory performance of the CPE connected to the public telecommunications networks. The CPE is not normally evaluated against performance, reliability or quality-of-service parameters.
7. The HKTA specifications and information notes issued by the TA can be downloaded from OFTA’s website at <http://www.ofta.gov.hk>. Enquiries about this specification may be directed to:

Senior Telecommunications Engineer
Standards Section
Office of the Telecommunications Authority
29/F Wu Chung House
213 Queen’s Road East
Wanchai
Hong Kong

Fax: +852 2838 5004
Email: standards@ofta.gov.hk

AMENDMENT TABLE

Item	Issue No.	Paragraph	Descriptions
1.	Issue 2	Foreword Para. 3-4 Para. 7	Update contact information for FTNS operators. Add information for HKTEC Scheme and classify CPE using DDI lines under CCS Cat. I Add new para. 7.
2.	Issue 2	Para. 2.2	Rewrite para. 2.2 to refer to HKTA 2001 on electrical safety requirement.
3.	Issue 2	Para. 3, 5, 6	Delete original public exchange condition and rewrite as note.
4.	Issue 2	Para. 4	Delete original public exchange condition and rewrite as para. 4.1.
5.	Issue 2	Para. 5.3	Recorded announcement is also accepted before the establishment of the answer condition.
6.	Issue 2	Para. 9	Rewrite para. 9.1.2 and para. 9.2 to refer to HKTA 2201 on technical characteristics of fixed telecommunications network.
7.	Issue 2	Para. 10.2.4 & 10.3.2	Delete original para. 10.2.4 & 10.3.2 for number of digits sent from public exchange and rewrite as note.
8.	Issue 2	Para. 11.7	Amend original para. 11.7 and put the return loss as a reference information.
9.	Issue 2	Para. 11.8	Delete original para 11.8 to 11.15 and group under the para. 11.8 on transmission performance.
10.	Issue 2	Appendix 1	Add reference information for return loss.
12.	Issue 2	Appendix 2	Add reference information for transmission performance.
13.	Issue 2	Annex 1	Add Technical Guide for Conducting Evaluation Test
14.	Issue 3	Foreword	Certification and labelling arrangements are updated.
15.	Issue 4	Foreword Annex 1, para. 1	Update information on certification and labelling as a result of the accreditation of Certification Bodies (CBs).
16.	Issue 4	Para. 2.2 & 17	The title of HKTA 2001 is updated
17	Issue 4	Para. 10.2.3, note 2 to figure 1	Amend the note to clarify that the delay dial signal is transmitted from the CPE.
18.	Issue 4	Para. 11.4.2 Annex 1, para. 3.13	Amend the text to clarify that RMS voltage of the out-band frequency components is to be measured.

19.	Issue 4	Annex 1, para. 2.2	Update the requirements for bandpass filter and spectrum analyzer.
20.	Issue 4	Annex 1, para. 3.10 - 3.12	Clarify the purposes of the tests.
21.	Issue 4	Annex 1, para. 3.12	Amend the text for the test state to clarify that music-on-hold, pre-recorded message (whether or not stored in the CPE), etc. may be used to simulate live voice.

CONTENTS

1. SCOPE
 2. ELECTRICAL SAFETY
 3. IDLE CONDITION
 4. SEIZURE CONDITION
 5. ANSWER CONDITION
 6. RELEASE CONDITION (CALLING PARTY RELEASES FIRST)
 7. RELEASE CONDITION (CALLED PARTY RELEASES FIRST)
 8. REMOTE BLOCKING
 9. SUPERVISORY TONES
 10. DIALLING SIGNAL FROM PUBLIC EXCHANGE (REGISTER SIGNALLING)
 11. TRANSMISSION REQUIREMENTS
 12. AUTOMATIC OPERATION
 13. TONE RECEIVER SENSITIVITY OF CPE
 14. TERMINATING (EXTENSION) INSTRUMENT OF MULTI-LINE OR SWITCHING EQUIPMENT
 15. INTERCONNECTION
 16. TERMINOLOGY
 17. REFERENCE DOCUMENTS
-
- APPENDIX 1 RETURN LOSS
- APPENDIX 2 TRANSMISSION PERFORMANCE
- ANNEX 1 TECHNICAL GUIDE FOR CONDUCTING EVALUATION TEST AGAINST HKTA 2013

1. SCOPE

This specification covers the technical requirements for connection of multi-line customer premises equipment (CPE) to direct-dial-in (DDI) lines of the Public Switched Telephone Network (PSTN).

2. ELECTRICAL SAFETY

2.1 PRINCIPLE OF PROTECTION

In order to safeguard operating personnel, users, and plant, it is essential to prevent the transmission of excessive voltages from the CPE into the public telecommunications network in Hong Kong.

2.2 SAFETY REQUIREMENTS

The CPE shall comply with specification HKTA 2001 titled "Compliance Test Specification - Safety and Electrical Protection Requirements for Subscriber Telecommunications Equipment" issued by the Telecommunications Authority (TA).

3. IDLE CONDITION

In idle condition, the CPE shall present a negative voltage on the B-wire and earth on the A-wire of the DDI line. The idle condition voltage on B-wire with respect to A-wire shall be between -50 V d.c. and -36 V d.c.

Note: To ensure satisfactory operation, the resistance of CPE's earth path should not exceed 3 Ω . In idle condition, the public exchange will present a d.c. resistance of not less than 38 k Ω across A and B wires of the DDI line.

4. SEIZURE CONDITION

4.1 The CPE shall be able to work with the following two seizure conditions:

- (i) The seizure signal from public exchange is a resistive circuit of not more than 1030 Ω excluding exchange line loop resistance which may be up to 1000 Ω depending on the line length.
- (ii) The seizure signal from public exchange is a constant current sink of 23 mA \pm 2 mA for operating voltage at CPE side (including line loop resistance) from -50 to -36 V d.c.

4.2 The CPE shall be capable of detecting the seizure signal from the public exchange. The d.c. current flowing in the seizure loop shall be such that when the DDI line interface of the CPE is connected to a test circuit with a load of 500 to 2030 Ω , the current flowing in the test circuit shall be contained within the range 17 to 130 mA.

5. ANSWER CONDITION

- 5.1 As soon as the DDI call is answered, the CPE shall return an answer signal to the public exchange, which shall be a polarity reversal of the pre-answer seizure condition such that the voltage on A-wire with respect to B-wire becomes negative and the loop current described in Clause 4.2 flows in the reverse direction.
- 5.2 The answer condition shall be maintained for the whole duration of the call and for at least 300 ms.
- 5.3 Supervisory tones described in Clause 9 shall be transmitted to the calling party through the public exchange before the establishment of the answer condition. In some occasions, recorded announcements will also be accepted.

Note: After detecting the answer signal from CPE, the public exchange will maintain the seizure loop. A minimum delay of 300 ms will elapse between the sending of the final digit and any switching action which may disturb the seizure loop condition.

6. RELEASE CONDITION (CALLING PARTY RELEASES FIRST)

- 6.1 When the disconnection of seizure loop from public exchange is present for longer than 140 ms, the CPE shall recognise it as a clear-forward signal and return a clear-backward signal to the public exchange between 150 and 700 ms of the initiation of the seizure-loop disconnection.
- 6.2 The clear-backward signal from CPE to public exchange shall be the restoration of the polarity of A and B wires to the idle condition such that the voltage on B-wire with respect to A-wire restores to be negative.

Note: When the calling party restores to on-hook, the public exchange will send a clear-forward signal to the CPE, which will be the disconnection of the seizure loop (i.e. restoration to be not less than 38 k Ω resistance across the A and B wires) for longer than 140 ms.

7. RELEASE CONDITION (CALLED PARTY RELEASES FIRST)

- 7.1 When the called party restores to on-hook, the CPE shall send a clear-backward signal to the public exchange. The clear-backward signal shall be the restoration of the polarity of A and B wires to the pre-answer seizure condition such that the voltage on B-wire with respect to A-wire restores to be negative.
- 7.2 Upon disconnection of the seizure loop, the CPE shall restore to the idle condition.

Notes: The response of the public exchanges to call release may be different in different FTNS networks. There are two scenarios:

- (i) For calls within the Hong Kong PSTN, upon detection of the clear-backward signal from CPE, the public exchange will return a clear-forward signal to the

CPE by disconnecting the seizure loop. The exchange will then be released after expiration of a release guard timing (0.7 to 2.0 s).

- (ii) In case the public exchange supports re-answer supervision, a re-answer supervision timing will commence at the public exchange on detection of the clear-backward signal from CPE.

If re-answer from the CPE is detected by the public exchange before expire, the supervision timing will be cancelled and the call connection will be maintained.

When the re-answer supervision timing expires or as soon as the calling party releases during the supervision timing, the public exchange will return a clear-forward signal to the CPE by disconnecting the seizure loop. The exchange circuit will then be released after expiration of a release guard timing (0.7 to 2.0 s).

8. REMOTE BLOCKING

- 8.1 The remote blocking (backward guard) signal from the CPE is used to indicate to the public exchange that the particular DDI line is out of service so that calls will be routed to other DDI lines.
- 8.2 The remote blocking signal shall be the removal of either earth from the A-wire or battery from the B-wire at the DDI line interface of the CPE.

9. SUPERVISORY TONES

9.1 GENERAL

- 9.1.1 Call progress indication in the form of supervisory tone shall be transmitted from the CPE to the caller within 6 seconds upon receipt of the final DDI digit. The answer condition described in Clause 5 shall be established before the transmission of any other information or announcement.
- 9.1.2 Application of supervisory tones shall be in accordance with Clause 5.2 of the HKTA 2201 titled "General Technical Characteristics of Fixed Telecommunications Networks in Hong Kong".

9.2 CHARACTERISTICS OF SUPERVISORY TONES

Supervisory tones transmitted from the CPE shall conform to Clause 5.3 of the HKTA 2201.

10. DIALLING SIGNAL FROM PUBLIC EXCHANGE (REGISTER SIGNALLING)

10.1 GENERAL

10.1.1 The DDI digits sent from public exchange will be available in the form of either DTMF signalling (Tone DDI Service) or loop-disconnect signalling (Pulse DDI Service). Tone DDI is preferred for fast call connection.

10.1.2 The CPE shall be capable of receiving the dialling signals from public exchange as described herein.

10.2 DTMF SIGNALLING FROM PUBLIC EXCHANGE

10.2.1 The public exchange can support either Immediate Start method or Delay Dial method for Tone DDI operation. The signalling method shall be specified by the equipment manufacturer/supplier.

10.2.2 For Immediate Start method, the public exchange will start to send the direct-dial-in digits by DTMF signalling when a minimum of 600 ms has elapsed after the seizure of the DDI line. The CPE shall conform to this timing.

10.2.3 For Delay Dial method, the CPE shall conform to the timing diagram shown in Figure 1 and Table 1.

Figure 1 - Timing Diagram of Delay Dial Method for DTMF Signalling over DDI Trunk

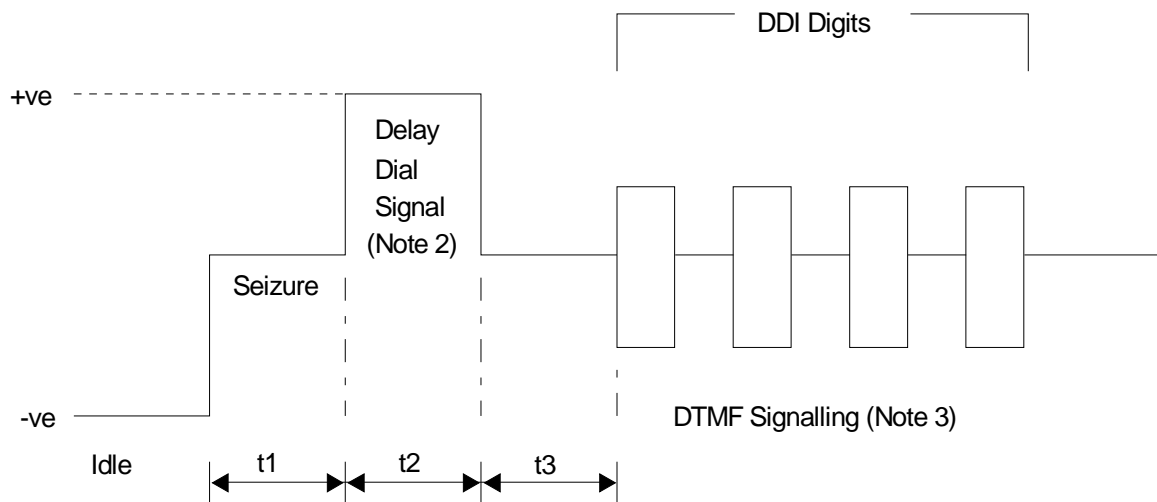

Table 1 - Delay Dial Method Timing Requirement

Timing	Description	Limit
t1	Duration between the beginning of seizure and the beginning of delay dial signal	4 s maximum (Note 1)

t2	Duration of the delay dial signal	140 ms minimum 4 s maximum
t3	Duration between the end of delay dial signal and the first DDI digit	80 ms minimum 300 ms maximum

Note 1: There is no minimum limit for t1 and the CPE can return the delay dial signal as soon as the seizure signal from the public exchange is detected.

Note 2: The delay dial signal is a momentary battery reversal transmitted from the CPE.

Note 3: Please refer to other items of Clause 10.2 for details of DTMF signalling sent from the public exchange.

10.2.4 The DTMF signal frequencies sent from the public exchange shall be in accordance with ITU-T Recommendation Q.23 as shown in Table 2.

Table 2 – Frequencies of DTMF Signal

Digit	Low Frequency Group (Hz)				High Frequency Group (Hz)			
	697	770	852	941	1209	1336	1477	1633
1	X				X			
2	X					X		
3	X						X	
4		X			X			
5		X				X		
6		X					X	
7			X		X			
8			X			X		
9			X				X	
0				X		X		
*				X	X			
#				X			X	

Note : 1633 Hz code is not used.

10.2.5 The frequency tolerance of the high and low frequency groups will be contained within $\pm 1.5\%$.

10.2.6 The duration of steady-state DTMF signal representing each digit will be within the range 61 to 75 ms.

10.2.7 The interdigital pause will be within the range 61 to 75 ms.

10.2.8 The power level of each frequency component of the high and low frequency groups will be within the range -12 to -16 dBm at the public exchange MDF. The CPE shall be capable of receiving DTMF signals with power level of each frequency component within the range -12 to -26 dBm at the DDI line interface of the CPE.

10.2.9 The level of each of the two frequency components will reach within ± 1 dB of the final value within 2 ms from the instant of the start of signal output.

10.2.10 Any steady-state signal power variation will be less than ± 0.5 dB.

10.2.11 During signalling, the power level of any individual unwanted frequency component, at the public exchange MDF, will be below the limit shown in Figure 2.

10.2.12 During signalling, the total power of all unwanted frequency components will be at least 20 dB below the level of sending signals.

10.2.13 When no DTMF signal is being sent, the total power of any signal emitted from the DTMF sender will be less than -76 dBm at the public exchange MDF.

Note: The public exchange will send two to four digits to the CPE.

Figure 2 - Limit on Power Level of Any Individual Unwanted Frequency Component

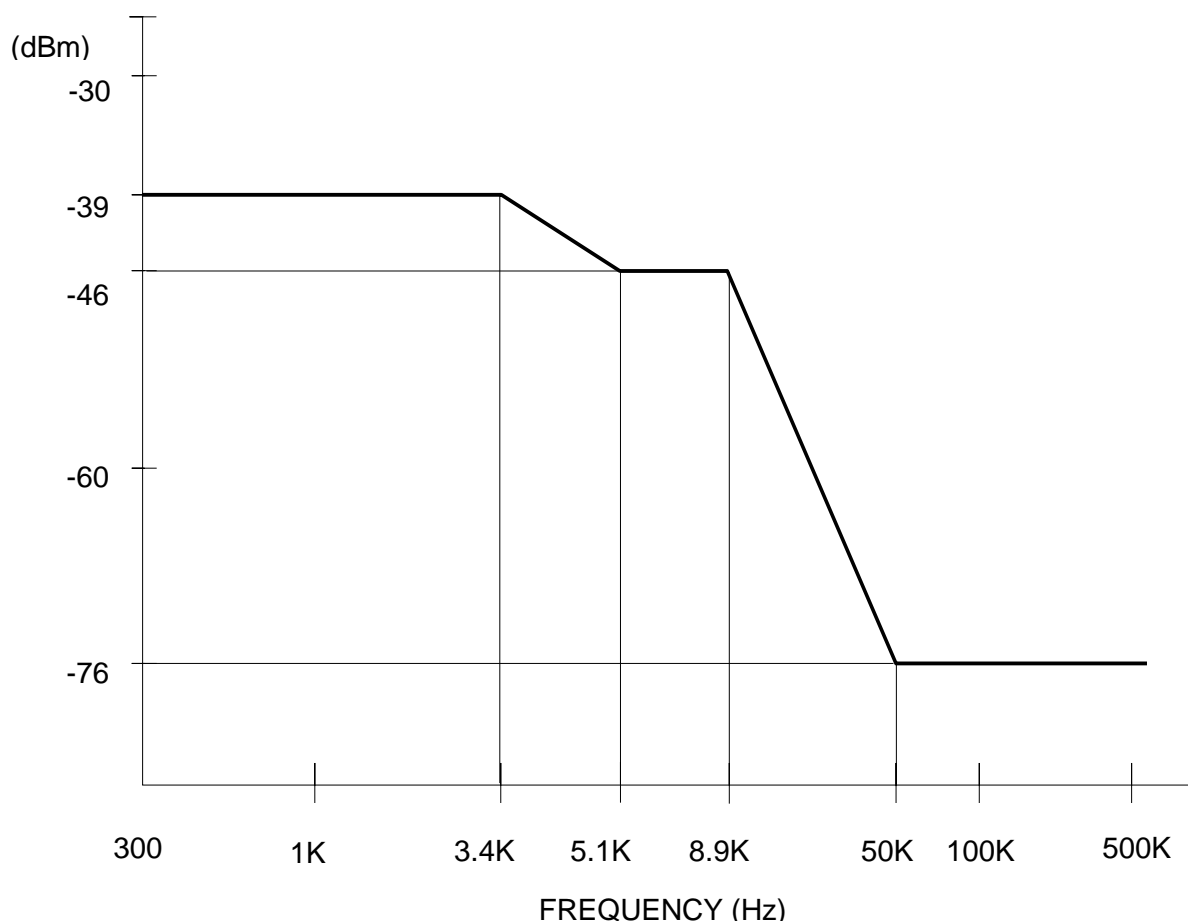

10.3 LOOP-DISCONNECT SIGNALLING FROM PUBLIC EXCHANGE

10.3.1 The public exchange only supports Immediate Start method for Pulse DDI operation and will start to send the direct-dial-in digits by loop-disconnect signalling when a minimum of 600 ms has elapsed after the seizure of the DDI line. For CPE using loop disconnect signalling, it shall recognise loop disconnect signals sent from the public exchange as specified in clauses 10.3.2 to 10.3.4.

10.3.2 The pulse rate will be 10 ± 1 pulses per second.

10.3.3 The break period will be 63 - 70% of the total pulse period.

10.3.4 The minimum interdigital pause will be 600 ms including one make period.

Note: The public exchange will send two to four digits to the CPE.

11. TRANSMISSION REQUIREMENTS

11.1 GENERAL

The PSTN has a nominal pass-band of 300 to 3400 Hz, with 600 Ω nominal non-reactive terminating impedance.

11.2 IN-BAND POWER LIMIT OF TONE SIGNALS

11.2.1 For continuous tone signals whose normal activity time is in excess of 30 seconds in one minute (e.g. data or facsimile transmission), the total power level of all transmitted signals in any 10 Hz band within the frequency range 0 to 4 kHz shall not exceed the limit shown in Figure 3 below, when measured at the DDI line interface of the CPE which is connected to a test circuit with a 600 Ω non-reactive terminating impedance and d.c. line current of 20 to 100 mA.

Figure 3 - In-Band Maximum Power Level

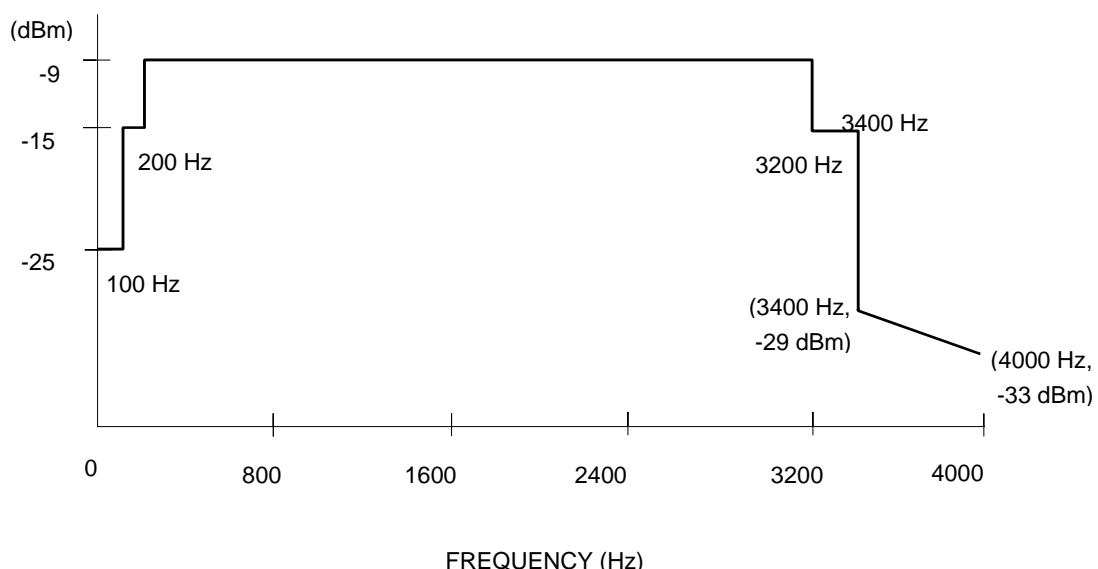

11.2.2 For non-continuous tone signals which have an activity time of 30 seconds or less in one minute, the total power level of all transmitted signals in any 10 Hz band within the frequency range 0 to 4 kHz shall not exceed the limit shown in Figure 2 above except that the limit from 200 to 3200 Hz is relaxed to a level of -5 dBm, when measured at the DDI line interface of the CPE which is connected to a test circuit with a 600 Ω non-reactive terminating impedance and d.c. line current of 20 to 100 mA.

11.3 IN-BAND POWER LIMIT OF SPEECH OR MUSIC SIGNALS

The power level of all transmitted speech or music signals (e.g. verbal announcement or music-on-hold), when averaged over any 3-second intervals, shall not exceed -9 dBm within the frequency range 300 to 4000 Hz, when measured at the DDI line interface of the CPE which is connected to a test circuit with a 600 Ω non-reactive terminating impedance and d.c. line current of 20 to 100 mA. To avoid acoustic shock, it is recommended that the sending power level of music-on-hold signals should be contained within -20 ± 2 dBm.

11.4 OUT-BAND POWER LIMIT

11.4.1 For frequencies in the range 4 kHz to 270 kHz, the root-mean-square (RMS) voltage averaged over 100 ms and measured across the DDI interface of the CPE shall not exceed the limits shown in Table 3.

Table 3 – Power Limit

Centre Frequency of 8 kHz Band (kHz)	Maximum Voltage in All 8 kHz Bands (dBV)	Terminating Impedance (Ω)
8 to 12	$-(6.4 + 12.6 \log f)$	300
12 to 90	$23 - 40 \log f$	135
90 to 266	-55	135

Where f = centre frequency in kHz of each of the possible 8 kHz bands beginning at 8 kHz, and
 dBV = $20 \log$ (voltage in volts).

11.4.2 The RMS voltage of the frequency components in the frequency range 270 kHz to 6 MHz, measured across the DDI interface of the CPE with a terminating impedance of 135 Ω, shall not exceed -15 dBV when averaged over 2 ms.

11.5 AUDIBLE TONES

The characteristics of the frequencies and cadences of audible tones transmitted from the CPE to the PSTN after a DDI call is answered shall be distinct and audibly dissimilar from the PSTN supervisory tones.

11.6 AMPLIFIER GAIN

In order to limit the level of crosstalk reproduction, any amplifier gain of the CPE shall be limited such that a signal level of -57 dBm or below appearing at the DDI line interface of the CPE will not be reproduced to an intelligible level.

11.7 RETURN LOSS

Reference information on the return loss of the CPE can be found in Appendix 1. The return loss does not constitute part of the CPE requirements for connection to DDI lines.

11.8 TRANSMISSION PERFORMANCE

Reference information on the transmission performance can be found in Appendix 2. The transmission performance does not constitute part of the CPE requirements for connection to DDI lines.

12. AUTOMATIC OPERATION

12.1 AUTOMATIC ANSWERING OF INCOMING CALLS

12.1.1 For automatic operation, upon answering of an incoming call by returning an answer signal (line reversal) to the PSTN, recorded announcement or appropriate handshake/identification signals shall be provided by the CPE.

12.1.2 Tone signals provided by the CPE after answering shall be distinct and audibly dissimilar from the PSTN supervisory tones.

Note: In cases where the CPE answers a call automatically and then provides a tone to the calling person (e.g. an interactive voice response system answers a call and then provides a tone to prompt the calling party to enter commands), it is preferred that a recorded announcement should be provided before sending the tone, in order to avoid misleading the calling party into thinking that the call has not been answered.

12.2 AUTOMATIC CALL RELEASE

CPE with automatic answering features or trunk-to-trunk connection features shall automatically release the DDI line (restore to idle state) immediately upon detection of clear-forward signal from the PSTN.

Note: In order to avoid false holding of exchange equipment as well as the CPE itself, it is preferred that all CPE with automatic operation should incorporate a time-out call release mechanism independent of the status of the calling party.

13. TONE RECEIVER SENSITIVITY OF CPE

Where the CPE's operation involves the detection of DTMF signals transmitted from the far-end subscriber's tone dialling telephone when a PSTN call path is established, the tone

receiver sensitivity of the CPE shall take account of the range of sending levels of DTMF signals from the far-end telephone as well as the PSTN call path attenuation. It is preferred that the tone receiver sensitivity of the CPE should enable detection of DTMF signals down to -39 dBm.

14. TERMINATING (EXTENSION) INSTRUMENT OF MULTI-LINE OR SWITCHING EQUIPMENT

- 14.1 All terminating instruments shall be considered as integral parts of the associated multi-line or switching equipment.
- 14.2 Under all combinations of terminating instruments, the multi-line or switching equipment shall conform to the relevant requirements contained in this specification.
- 14.3 It is the manufacturer/supplier's responsibility to ensure satisfactory interworking and interconnection of the terminating instruments with the other parts of the multi-line or switching equipment.

15. INTERCONNECTION

For the connection of multi-line CPE, hard-wired termination is usually employed in lieu of modular plugs and sockets. The network operator will provide an Interconnect Point (IP) between the CPE and the network. All wiring within the IP (e.g. Interface Disconnection Box with Krone strips) will be connected and disconnected by the network operator. The manufacturer/supplier of the CPE will provide the cabling to the CPE side of the IP.

16. TERMINOLOGY

For the purpose of this specification, the following definitions shall apply.

- A and B Wires - A DDI line has two wires or conductors which are designated the A-wire and the B-wire respectively.
- Extension Port - The termination point of extension line cable, remote from the main unit of the multi-line or switching equipment, where the terminating instrument is connected.
- Multi-Line or Switching Equipment - Customer premises equipment, including all DDI equipment and others, which are capable of switching/routing of PSTN calls involving more than one exchange line and/or more than one terminating extension. Typical examples are PABX systems, key telephone systems and dealerboard systems.
- Terminating Instrument - Equipment connected to the extension line of a multi-line or switching equipment.

17. REFERENCE DOCUMENTS

- [1] “General Recommendations on Telephone Switching and Signalling”, Recommendations of the Q Series, ITU-T Blue Book, 1988.
- [2] “Telephone Transmission Quality”, Recommendations of the P Series, ITU-T Blue Book, 1988.
- [3] HKTA 2001 - “Compliance Test Specification - Safety and Electrical Protection Requirements for Subscriber Telecommunications Equipment” issued by the TA.
- [4] HKTA 2011 - “Network Connection Specification for Connection of Customer Premises Equipment (CPE) to Direct Exchange Lines (DEL) of the Public Switched Telephone Network (PSTN) in Hong Kong” issued by the TA.
- [5] HKTA 2201 - “General Technical Characteristics of the Fixed Telecommunications Networks in Hong Kong” issued by the TA.

- END -

RETURN LOSS

The following is reference information about the recommended return loss of CPE.

For better transmission performance, the CPE may be designed with a suitable return loss presented to the DDI against a reference impedance of 600 ohms over the frequency range between 300 to 4000 Hz and measured with d.c. line current of 20 to 100 mA.

Note 1: Return loss is determined from the following expression :

$$20 \log_{10} \left| \frac{Z_r + Z_m}{Z_r - Z_m} \right| \text{ dB}$$

Where Z_r is the reference impedance (600 ohms), and Z_m is the measured value of impedance of the DDI line interface of the CPE at d.c. line current of 20 to 100 mA, over the frequency range 300 to 4000 Hz.

Note 2: It is recommended that the return loss of the CPE as determined by the above expression is greater than 9 dB.

TRANSMISSION PERFORMANCE

The following is reference information about the recommended transmission performance for CPE.

(a) Transmission Loss

The nominal transmission loss in a PSTN call path between the extension port and the DDI line interface of the CPE including switching loss and extension cabling loss does not exceed 2 dB at the reference frequency of 1020 Hz, when tested with an input signal of -10 dBm0.

(b) Variation of Loss with Signal Frequency

The variation of transmission loss with signal frequency, relative to the loss at an input signal of -10 dBm0 at the reference frequency of 1020 Hz, conforms to the limits shown below. The symbol “+” denotes more loss; the symbol “-” denotes less loss than measured at the reference frequency.

Frequency	Loss Variation
300 to 500 Hz	-0.5 to +2.0 dB
500 to 3000 Hz	-0.5 to +1.0 dB
3000 to 3400 Hz	-0.5 to +3.0 dB

(c) Variation of Loss with Signal Level

The variation of transmission loss with signal level, relative to the loss at an input signal of -10 dBm0 at the reference frequency of 1020 Hz, conforms to the limits shown below.

Input Level	Loss Variation
+3 to -40 dBm0	±0.5 dB
-40 to -50 dBm0	±1.0 dB
-50 to -55 dBm0	±3.0 dB

(d) Noise

With the extension port and the DDI line interface both terminated by 600 ohm nominal impedance, the noise at the extension port and the DDI line interface does not exceed -65 dBmp.

(e) Crosstalk

With a sinusoidal signal at reference frequency of 1020 Hz at a level of 0 dBm0 applied to the extension port or the DDI line interface, the crosstalk level received at any other extension port or line interface does not exceed -65 dBm0.

(f) Delay

The minimum propagation delay introduced into a call path between the extension port and the DDI line interface, at a frequency within the band 300 to 3400 Hz, does not exceed 3 ms.

With the minimum propagation delay described above taken as a reference, the maximum relative delay at other frequencies in the band does not exceed the limits shown below.

Input Frequency	Maximum Relative Delay
500 to 600 Hz	1.5 ms
600 to 1000 Hz	0.75 ms
1000 to 2600 Hz	0.25 ms
2600 to 2800 Hz	1.5 ms

(g) Trunk-to-Trunk Connection, Tie Line Network and External Extension

Application of trunk-to-trunk connection (call-forwarding, call-transfer, conference call, etc.), tie line network or external extension does not cause degradation of the transmission performance of a PSTN call path. In some cases, amplification may be required to compensate the additional line loss.

Note: It is preferred that the digital trunk services and digital data services for PSTN and private network/tie line connections respectively should be used in order to avoid degradation of transmission performance.

(h) Longitudinal Balance (Impedance Unbalance about Earth)

The longitudinal balance, or impedance unbalance about earth, is defined as $20 \log |E/V|$, where E is the disturbing longitudinal voltage and V is the resulting metallic voltage at the same frequency. To avoid significantly degrading transmission quality, the longitudinal balance does exceed 40 dB over the frequency range 50 to 3400 Hz.

**TECHNICAL GUIDE FOR
CONDUCTING EVALUATION TEST AGAINST HKTA 2013**

1. INTRODUCTION

This guide describes the conditions and procedures for reference of the manufacturers and recognised testing agencies to conduct the evaluation test of customer premises equipment (CPE) against HKTA 2013.

The scope of this guide covers only testing of electrical characteristics of the CPE using Direct-Dial-In (DDI) lines for connection to the public telecommunications networks. However, those related to safety and electrical protection are excluded.

For the purpose of certification, compliance of the CPE with HKTA 2013 should be determined in accordance with this guide as far as possible.

In the event of conflict between HKTA 2013 and this guide, HKTA 2013 takes precedence.

2. TEST CONDITIONS

2.1 Test Environment

All tests should be performed under non-condensing conditions at:

- an ambient temperature in the range from +15°C to +35°C
- a relative humidity in the range from 10% to 80%

2.2 Suggested Equipment List

The suggested requirements for the measurement equipment needed to perform the tests in this guide are as follows:

- Resistors: accuracy $\pm 1\%$
- DC voltmeter: input impedance $> 1\text{ M}\Omega$, range 0 V to 80 V, accuracy $\pm 3\%$
- DC ammeter: range 0 mA to 100 mA, accuracy $\pm 3\%$
- Bandpass filter: cutoff frequency at 3 dB attenuation points, out-of-band roll-off $> 24\text{ dB}$ per octave
- Spectrum analyzer: frequency range up to 6 MHz, resolution bandwidth down to 10 Hz, accuracy $\pm 1\%$ for frequency measurement and $\pm 2\text{ dB}$ for power measurement
- Digital storage oscilloscope: input impedance $> 1\text{ M}\Omega$, frequency range up to 6 MHz, accuracy $\pm 3\%$
- Frequency counter: input impedance $> 1\text{ M}\Omega$, frequency range up to 6 MHz, resolution $< 1\text{ Hz}$, accuracy $\pm 1\%$

3. TEST PROCEDURES

3.1 General

The test procedures for the relevant clauses of HKTA 2013 which involve electrical characteristics of CPE are contained in the Section 3.2 to Section 3.13 of this guide.

The test procedures specified in this guide are not exclusive and alternative procedures that are equivalent to those specified may be used. The test configurations given in this guide do not imply a specific realisation of measurement equipment or arrangement or use of specific measurement devices for the compliance testing. The measurement equipment shall be a single device, or group of devices, generating a stimulus signal and providing test conditions conforming to this guide and capable of measuring the signal from the measurement point.

To determine the compliance of CPE, all results of measurements taken in Section 3.2 to 3.13 should meet the requirements given in the relevant Clauses of HKTA 2013.

3.2 Idle Condition - Clause 3 of HKTA 2013

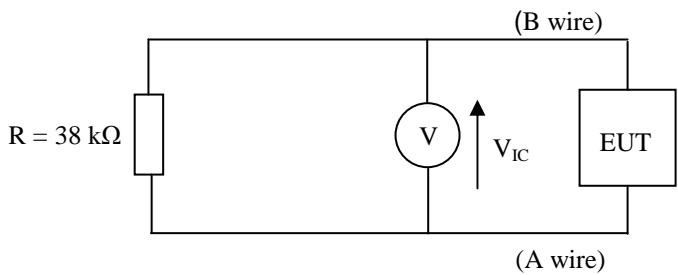
Purpose:	To check the line voltage under the idle state.
Test State:	Idle state.
Test Configuration:	
Measurement:	a) Measure the d.c. voltage V_{IC} .
Verdict:	If the measured voltage V_{IC} meets the requirement given in Clause 3 of HKTA 2013 then Pass; else Fail.

3.3 Seizure Condition - Clause 4 of HKTA 2013

Part 1 – Clause 4.1 of HKTA 2013

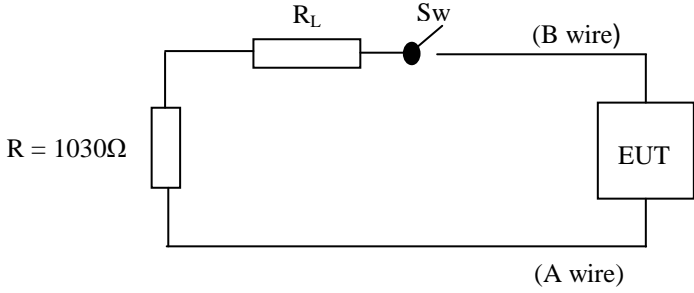
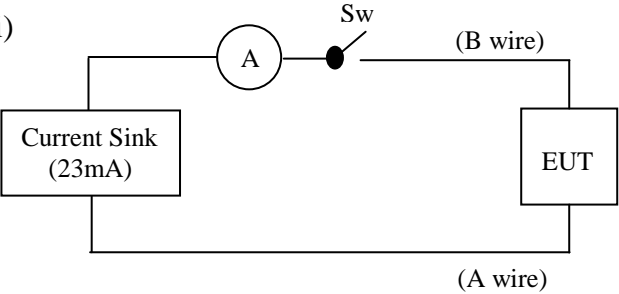
Purpose:	To check the response of the EUT under the seizure state.
Test State:	Seizure state.
Test Configuration:	<p>Case (i)</p>  <p>Set $R_L = 1000\Omega$ then repeat for $R_L = 0\Omega$</p> <p>Case (ii)</p> 
Measurement:	a) Close Sw and check the response of the EUT.
Verdict:	If the EUT can be able to work with the above two seizure conditions given in Clause 4.1 of HKTA 2013 then Pass; else Fail.

Part 2 – Clause 4.2 of HKTA 2013

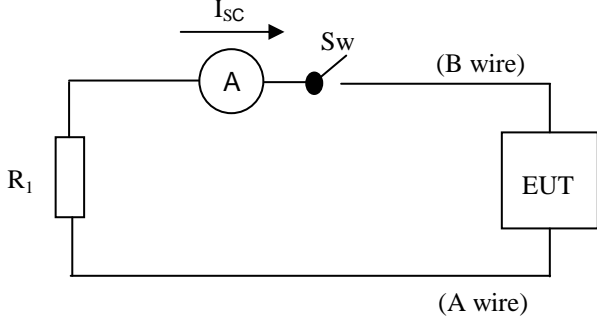
Purpose:	To check the response of the EUT under the seizure state.
Test State:	Seizure state.
Test Configuration:	 <p>The diagram illustrates a series circuit used for testing the EUT under seizure conditions. The circuit includes a resistor R_1, an ammeter labeled 'A', a switch labeled 'Sw', and the EUT (Equipment Under Test). The current flowing through the circuit is denoted as I_{SC}. The EUT is connected to the circuit through two wires: '(A wire)' and '(B wire)'.</p>
Measurement:	<p>a) Close Sw for $R_1 = 500 \Omega$ and check the response of the EUT and the current I_{SC}.</p> <p>b) Close Sw for $R_1 = 2030 \Omega$ and check the response of the EUT and the current I_{SC}.</p>
Verdict:	If the EUT can be able to work with the seizure condition and the current I_{SC} is within the range given in Clause 4.2 of HKTA 2013 then Pass; else Fail.

3.4 Answer Condition - Clause 5 of HKTA 2013

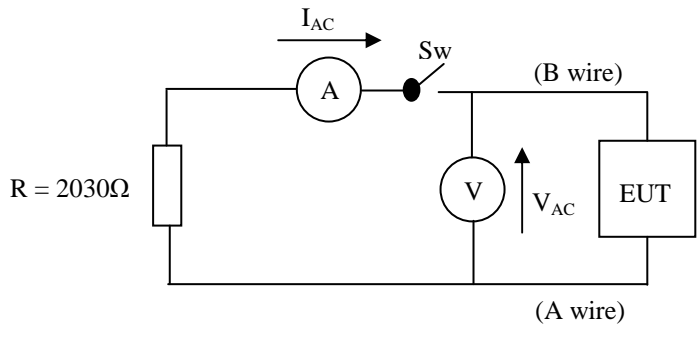
Purpose:	To check the line polarity under the answer state.
Test State:	Answer state.
Test Configuration:	
Measurement:	<p>a) Close Sw and measure the d.c. current I_{AC} and voltage V_{AC} in the seizure state.</p> <p>b) When EUT returns the answer signal, measure the d.c. current I_{AC} and voltage V_{AC}.</p>
Verdict:	<p>If the polarity of the measured d.c. voltage V_{AC} in b) and a) is reversed and the direction of the measured d.c. current I_{AC} in b) and a) is reversed then Pass; else Fail.</p> <p>Note:</p> <p>i) The answer condition shall be maintained for whole duration for at least 300ms.</p> <p>ii) Supervisory tones (or recorded announcement) shall be sent by EUT before the establishment of the answer condition.</p>

3.5 Release Condition(Calling Party Release First) - Clause 6 of HKTA 2013

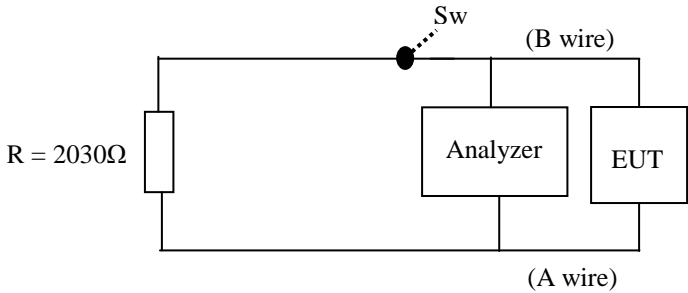
Purpose:	To check the release condition under calling party release first.
Test State:	Answer state.
Test Configuration:	
Measurement:	a) Under the answer condition, open Sw to simulate the disconnection of seizure loop, monitor the clear-backward signal sent from EUT.
Verdict:	If the timing to generate clear-backward signal and the polarity of the A and B wires meet the requirement given in Clause 6 of HKTA 2013 then Pass; else Fail.

3.6 Release Condition (Called Party Release First) - Clause 7 of HKTA 2013

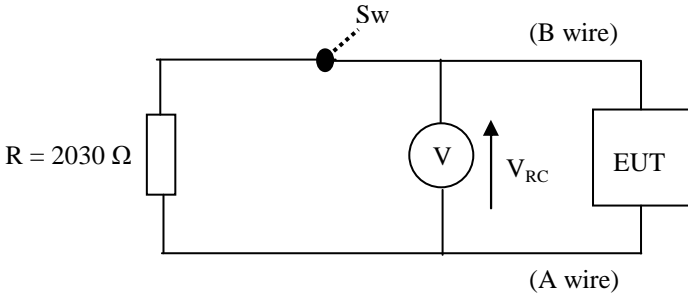
Purpose:	To check the release condition under called party release first.
Test State:	Answer state.
Test Configuration:	
Measurement:	a) Under the answer condition, check the voltage V_{RC} when EUT sends out the clear-backward signal (Sw then in open state).
Verdict:	<p>If the measured voltage V_{RC} meets the requirement given in Clause 7 of HKTA 2013 then Pass; else Fail.</p> <p>Note:</p> <p>i) Upon disconnection of the seizure loop, the EUT shall restore to the idle condition.</p>

3.7 Remote Blocking - Clause 8 of HKTA 2013

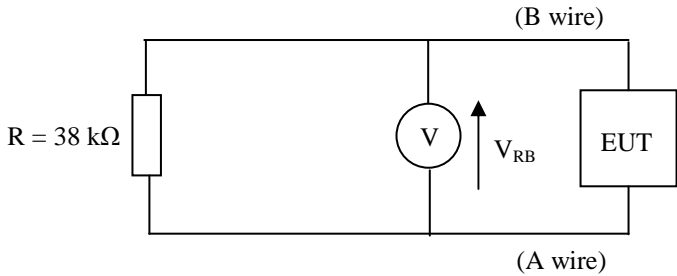
Purpose:	To check the remote blocking capability of EUT.
Test State:	Remote blocking state.
Test Configuration:	 <p>The diagram shows a circuit with two horizontal wires, (B wire) at the top and (A wire) at the bottom. On the left, a vertical resistor labeled $R = 38\text{ k}\Omega$ connects the two wires. In the center, a voltage source (a circle with 'V' and an upward arrow) connects the two wires. On the right, a rectangular box labeled 'EUT' connects the two wires. An upward arrow labeled V_{RB} indicates the voltage across the EUT.</p>
Measurement:	a) Measure the voltage V_{RB} under remote blocking state.
Verdict:	If the measured voltage V_{RB} meets the requirement given in Clause 8 of HKTA 2013 then Pass; else Fail.

3.8 DTMF Signalling from Public Exchange – Clause 10.2 of HKTA 2013

Part 1

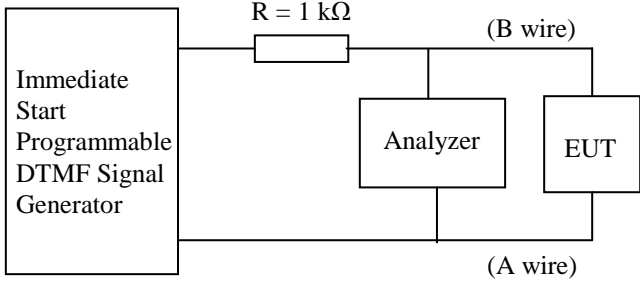
Purpose:	To check the reception of DTMF digits based on Immediate Start method.
Test State:	Seizure state.
Test Configuration:	 <p>Setting of the DTMF Signal Generator</p> <ul style="list-style-type: none"> • Seizure time = 600 ms • DTMF signal duration = 61 to 75 ms • Interdigital pause = 61 to 75 ms • Power level of each frequency component of DTMF signal = -26 dBm
Measurement:	a) Program the DTMF signal generator to simulate the sending of digits 1590.
Verdict:	If the EUT can receive the digits 1590 then Pass; else Fail.

Part 2

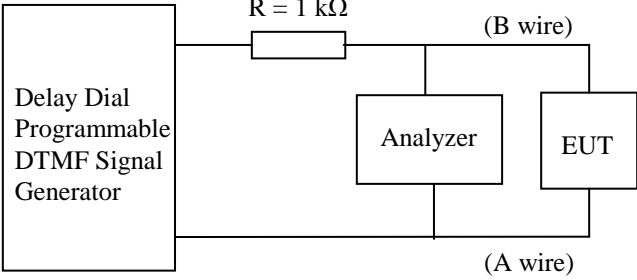
Purpose:	To check the reception of DTMF digits based on Delay Dial method.
Test State:	Seizure state.
Test Configuration:	<div style="text-align: center;">  </div> <p>Setting of the DTMF Signal Generator</p> <ul style="list-style-type: none"> • Program the timing of the timers in accordance with Figure 1 of HKTA 2013 • DTMF signal duration = 61 to 75 ms • Interdigital pause = 61 to 75 ms • Power level of each frequency component of DTMF signal = -26 dBm
Measurement:	b) Program the DTMF signal generator to simulate the sending of digits 1590.
Verdict:	If the EUT can receive the digits 1590 then Pass; else Fail.

3.9 Loop-Disconnect Signalling from Public Exchange – Clause 10.3 of HKTA 2013

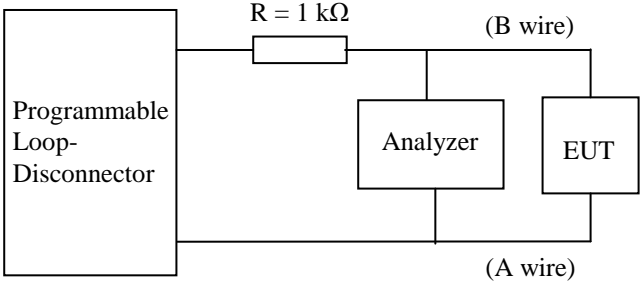
Purpose:	To check the reception of loop-disconnect pulses.
Test State:	Seizure state.
Test Configuration:	 <p>Setting of Programmable Loop-Disconnecter</p> <ul style="list-style-type: none"> • Seizure time = 600 ms • Pulse rate = 9 – 11 pulses per sec • Break period = 63 – 70 % of the total pulse period • Interdigital pause = 600 ms including one make period
Measurement:	a) Program the loop-disconnector to simulate the sending of digits 150.
Verdict:	If the EUT can receive the digits 150 then Pass; else Fail.

3.10 Continuous Tone Signal - Clause 11.2.1 of HKTA 2013

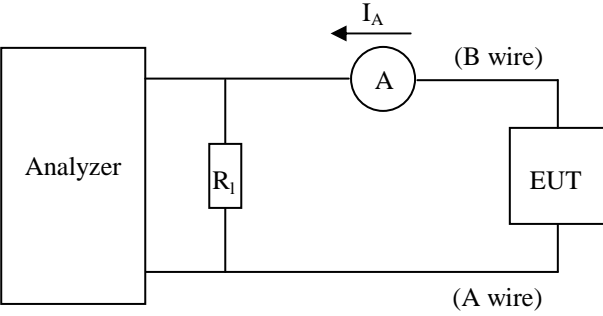
Purpose:	To check the in-band power level of the continuous tone signals transmitted from CPE.
Test State:	Answer state with continuous tone signals on.
Test Configuration:	 <p style="text-align: center;"> $R_1 = 600 \Omega$ $20 \text{ mA} < I_A < 100 \text{ mA}$ </p>
Measurement:	a) Measure the signal power across R_1 in each 10Hz band within the frequency range 0 to 4 kHz.
Verdict:	If results of power measurement meet the requirement given in Figure 3 of HKTA 2013 then Pass; else Fail.

3.11 Non-continuous Tone Signals - Clause 11.2.2 of HKTA 2013

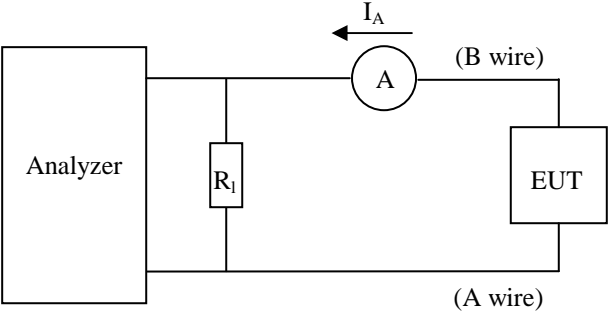
Purpose:	To check the in-band power level of the non-continuous tone signals (i.e. activity time of 30 seconds or less in one minute) transmitted from CPE.
Test State:	Answer state with non-continuous tone signals on.
Test Configuration:	 <p style="text-align: center;">$R_1 = 600 \Omega$ $20 \text{ mA} < I_A < 100 \text{ mA}$</p>
Measurement:	a) Measure the signal power across R_1 in each 10Hz band within the frequency range 0 to 4 kHz.
Verdict:	If results of power measurement meet the requirement given in Clause 11.2.2 of HKTA 2013 then Pass; else Fail.

3.12 In Band Power Limit of Speech or Music Signals - Clause 11.3 of HKTA 2013

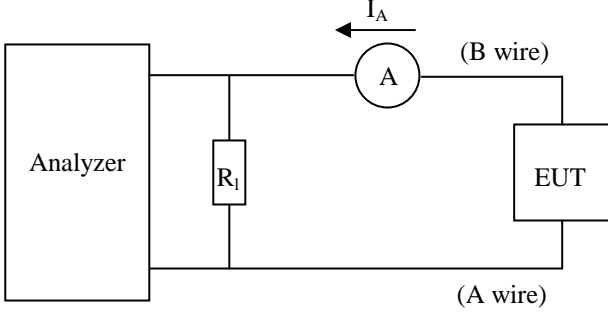
Purpose:	To check the in-band power level of the speech or voice signals transmitted from CPE.
Test State:	Answer state with voice signals (music-on-hold, recorded message (whether or not stored in the CPE), etc. may be used to simulate live voice) on.
Test Configuration:	 <p> $R_1 = 600 \Omega$ $20 \text{ mA} < I_A < 100 \text{ mA}$ </p>
Measurement:	a) Measure the signal power, averaged over 3-second interval, across R_1 within the frequency range 300 to 4000 Hz.
Verdict:	If result of power measurement meets the requirement given in Clause 11.3 of HKTA 2013 then Pass; else Fail.

3.13 Out-band Power Limits - Clause 11.4 of HKTA 2013

Part 1 – Clause 11.4.1 of HKTA 2013

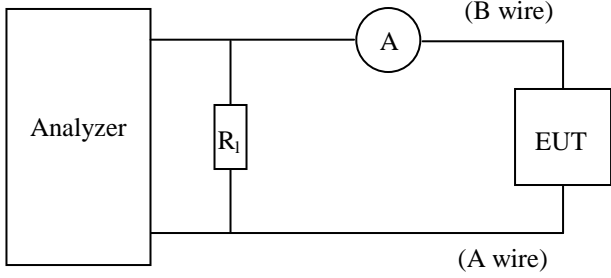
Purpose:	To check the out-band power transmitted under the answer state.
Test State:	Answer state.
Test Configuration:	 <p> $R_1 = 300 \Omega$ for centre frequency of 8 kHz band from 8 kHz to 12 kHz $R_1 = 135 \Omega$ for centre frequency of 8 kHz band from 12 kHz to 266 kHz </p>
Measurement:	a) Measure the RMS voltage, averaged over 100 ms, across R_1 in each 8 kHz band whose centre frequency is in the range of 8 kHz to 266 kHz.
Verdict:	If the measured RMS voltages meet the requirement given in Table 3 of HKTA 2013 then Pass; else Fail.

Part 2 – Clause 11.4.2 of HKTA 2013

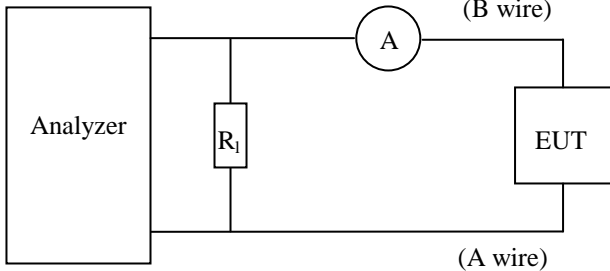
Purpose:	To check the out-band power transmitted under the answer state.
Test State:	Answer state.
Test Configuration:	 <p>$R_1 = 135 \Omega$</p>
Measurement:	b) Measure the RMS voltage of the frequency components, averaged over 2 ms, across R_1 in the range of 270 kHz to 6 MHz.
Verdict:	If the measured RMS voltage meets the requirement given in Clause 11.4.2 of HKTA 2013 then Pass; else Fail.