

HKTA 2014  
ISSUE 5  
JANUARY 2008

**NETWORK CONNECTION SPECIFICATION  
FOR CONNECTION OF  
CUSTOMER PREMISES EQUIPMENT (CPE)  
TO THE PUBLIC TELECOMMUNICATIONS  
NETWORK (PTN) IN HONG KONG  
USING ISDN BASIC RATE ACCESS (BRA)  
BASED ON ITU-T RECOMMENDATIONS**



**TELECOMMUNICATIONS AUTHORITY  
HONG KONG**

## **FOREWORD**

1. This specification is issued pursuant to Section 32D of the Telecommunications Ordinance (Cap. 106). This specification sets out the technical requirements of customer premises equipment (CPE) which uses Basic Rate Access (BRA) and is to be connected to Integrated Services Digital Network (ISDN) based on International Telecommunication Union – Telecommunication (ITU-T) recommendations.
2. The following services are classified as basic services and transparent communication of ISDN terminal equipment connected to different ISDNs is supported:
  - (a) basic voice and data communications by using the B channels;
  - (b) Calling Line Identification Presentation;
  - (c) Calling Line Identification Restriction;
  - (d) Multiple Subscriber Number;
  - (e) Subaddressing; and
  - (f) Group 4 fax transmission.

The three services (a), (b) and (c) above are the minimum services which must be included by the operators offering ISDN services in their portfolio. For ISDN services other than the basic services, they will be offered by individual operators at their own discretion.

3. ISDN services may be provided by any one of the Fixed Telecommunications Network Services (FTNS) operators in Hong Kong. CPE should comply with this specification for connection to the ITU-T based BRA ISDN line provided by the FTNS operators. Supplementary information on network characteristics and services of the FTNS networks may be obtained direct from the operators. Contact information of the FTNS operators can be found in the information note OFTA I 412.
4. At present, the Office of the Telecommunications Authority (OFTA) operates a **Hong Kong Telecommunications Equipment Evaluation and Certification (“HKTEC”)** scheme. Details of the scheme can be found in the information note OFTA I 421. Under the scheme, suppliers or manufacturers may apply to OFTA for certification of their customer premises equipment against this specification. The application procedures for certification of customer premises equipment can be found in the information note OFTA I 412. A prescribed label may be affixed to the equipment which has been certified by the Telecommunications Authority (TA). Details of the labelling arrangement can be found in the Standardisation Guide HKTA 3211.
5. The TA may amend any part of this specification as and when he deems necessary.
6. In case of doubt about the interpretation of this specification, the methods of carrying out the test and the validity of statements made by the manufacturers of the equipment, the decision of the TA shall be final.
7. The TA accepts no responsibility for the satisfactory performance of the CPE connected to the public telecommunications networks. The CPE is not normally evaluated against performance, reliability or quality-of-service parameters.

8. The HKTA specifications and information notes issued by the TA can be obtained through one of the following methods:-
- Downloading direct through the OFTA's Internet Home Page. The Home Page address is <http://www.ofta.gov.hk>;
  - Making a request for hard copies to:-

Senior Telecommunications Engineer  
Standards Section  
Office of the Telecommunications Authority  
29/F Wu Chung House  
213 Queen's Road East  
Wanchai  
Hong Kong

Fax: +852 2838 5004  
Email: standards@ofta.gov.hk

9. Enquiries about this specification may be directed to:-

Senior Telecommunications Engineer  
Standards Section  
Office of the Telecommunications Authority  
29/F Wu Chung House  
213 Queen's Road East  
Wanchai  
Hong Kong

Fax: +852 2838 5004  
Email: standards@ofta.gov.hk

## AMENDMENT TABLE

Item	Issue No.	Paragraph	Descriptions
1.	Issue 2	Foreword Para. 4	Update contact information for FTNS operators.
2.	Issue 2	Foreword Para. 6-7	Add information for HKTEC Scheme
3.	Issue 2	Section I – 3	The electrical safety requirement is referred to HKTA 2001.
4.	Issue 2	Section I – 7	The information of supervisory tones is referred to HKTA 2201.
5.	Issue 3	Foreword	Certification and labelling arrangements are updated.
6.	Issue 4	Clause 3.1 of Part E, in Section II	The description on CND function is modified.
7.	Issue 5	Clause 7.1	Reference to ITU-T Recommendation P.31 is changed to P.310 as P.31 has been withdrawn with its content incorporated in P.310.
8.	Issue 5	Clause 9	ITU-T Recommendation E.163 is removed from the list of reference documents as E.163 has been withdrawn with its content incorporated in E.164.  ITU-T Recommendation P.31 is changed to P.310.
9.	Issue 5	Clauses 2.2 and 2.3 of Part E, in Section II	Editorial changes - clauses 2.1.2.18 and 2.1.2.19 are renumbered to clauses 2.2 and 2.3 respectively, in line with ITU-T Recommendation Q.931 (I.451).

## **CONTENTS**

### **SECTION I - INTRODUCTION**

1. Scope
2. Organisation of Document
3. Electrical Safety
4. Interconnect Point
5. Definition
6. Summary of Capabilities
7. Characteristics of Digital Phones and Voice Ports
8. Propagation Delay
9. Reference Documents

### **SECTION II - TECHNICAL SPECIFICATIONS**

- Part A ISDN Basic Rate User-Network Interface Layer 1 Specification  
Compliance With ITU-T Recommendation I.430
- Part B ISDN User-Network Interface Data Link Layer General Aspects (Basic Rate Access)  
Compliance With ITU-T Recommendation Q.920 (I.440)
- Part C ISDN User-Network Interface Data Link Layer Specification (Basic Rate Access)  
Compliance With ITU-T Recommendation Q.921 (I.441)
- Part D ISDN User-Network Interface Layer 3 General Aspects (Basic Rate Access)  
Compliance With ITU-T Recommendation Q.930 (I.450)
- Part E ISDN User-Network Interface Layer 3 Specification for Basic Call Control  
(Basic Rate Access)  
Compliance With ITU-T Recommendation Q.931 (I.451)
- Appendix A Usage of Cause Values

## SECTION I - INTRODUCTION

## 1. **SCOPE**

This Network Connection Specification defines the requirements for the access protocol for interconnection between the FTNS operator's network and user's equipment (e.g. a terminal or terminal adapter) using Basic Rate Access (BRA) of Integrated Services Digital Network (ISDN). The protocol shall be applied to the S/T reference point as defined in the ITU-T Rec. I.430. ISDN terminal equipment intended to be connected to the ISDN by BRA in Hong Kong based on ITU-T recommendations shall comply with this specification.

The layered protocol defined in this document is based on the ITU-T I-Series Recommendations I.430, I.440 (Q.920), I.450 (Q.930) and I.451 (Q.931). All definitions and descriptions contained in these Recommendations apply, except where contradicted by this and associated documents.

This Specification only stipulates the technical requirements on the physical layer, data link layer and network layer protocols for a user to access to the ISDN using BRA.

## 2. **ORGANIZATION OF THIS DOCUMENT**

This Specification is organised into 2 sections. Section I is the introduction. Section II contains five parts covering the technical requirements for layers 1, 2 and 3 respectively. Appendix A describes the usage of cause values. The ISDN basic rate access protocol is based on related ITU-T Recommendations including:

Part A - I.430 "Basic Rate User-Network Interface Layer 1 Specification"

Part B - Q.920 (I.440) "ISDN User-Network Interface Data Link Layer General Aspects"

Part C - Q.921 (I.441) "ISDN User-Network Interface Data Link Layer Specification"

Part D - Q.930 (I.450) "ISDN User-Network Interface Layer 3 General Aspects"

Part E - Q.931 (I.451) "ISDN User-Network Interface Layer 3 Specification For Basic Call Control"

Appendix A - Usage of Cause Value

### 3. **ELECTRICAL SAFETY**

#### 3.1 PRINCIPLE OF PROTECTION

In order to safeguard operating personnel, users and plant, it is essential to prevent the transmission of excessive voltages from the CPE into the public telecommunication network in Hong Kong.

#### 3.2 SAFETY REQUIREMENTS

The CPE shall comply with specification HKTA 2001 titled “Compliance Test Specification – Safety and Electrical Protection Requirements for Subscriber Equipment Connected to the Public Telecommunications Networks in Hong Kong” issued by the Telecommunications Authority (TA).

### 4. **INTERCONNECT POINT**

4.1 The interconnect point marks the division of responsibility between the network service provider and the customer (please see Figure 1 below).

4.2 The operator will provide ISO 8877 8-pole jack(s) [see Figure 2(a)] with appropriate wiring configuration at the interconnect point within the customer premises. Space with ventilation may be required to install the operator’s equipment for providing the interconnect point. The customer is required to provide appropriate cords with plugs [see Figure 2(b)] for connecting the CPE to the jack(s).

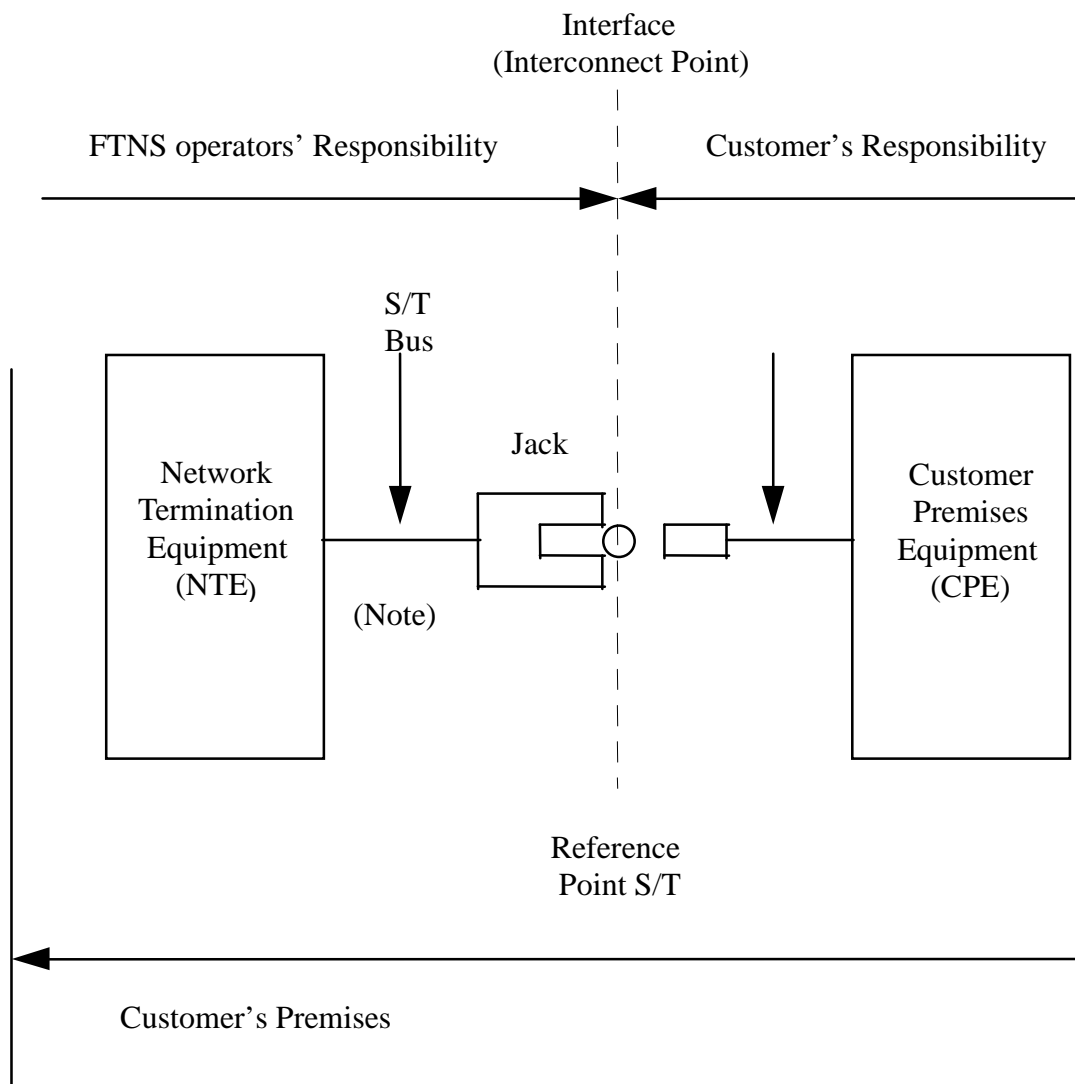

Note : Maximum two jacks will be provided for connection

Figure 1 Interconnection of CPE to FTNS operators' ISDN BRA service at Interconnect

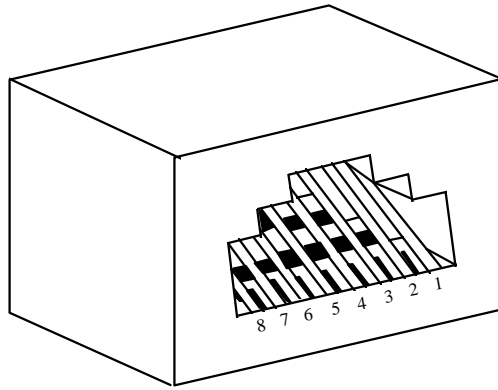

Figure 2(a) 8-Pole Jack

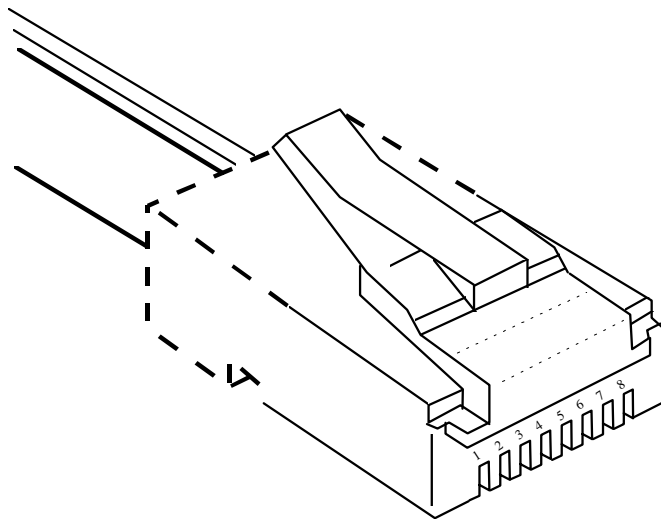

Figure 2(b) 8-Pole Plug

## 5. DEFINITION

- D-channel- A 16 kbit/s channel carrying signalling (refer to ITU-T Rec. I.412)
- B-channel- A 64 kbit/s channel that carries user information such as circuit switched data, etc. (refer to ITU-T Rec. I.412)
- USER - User equipment, e.g. terminal.
- NT - Network Termination, is used to indicate network terminating aspects of NT1 functional group.
- NT1 - Network Termination 1, includes functions broadly equivalent to layer 1 (physical) of the OSI reference model.
- NT2 - Network Termination 2, includes functions broadly equivalent to layer 1 and higher layers of the ITU-T Recommendation X.200 reference model.
- TE - Terminal Equipment, is used to indicate terminal terminating aspects of TE1 or TE2 functional group which includes functions broadly belonging to layer 1 and higher layers of the ITU-T Recommendation X.200 reference model.
- TE1 - Terminal Equipment Type 1, has an interface that complies with the ITU-T ISDN user-network interface Recommendations.
- TE2 - Terminal Equipment Type 2, has an interface that complies with interface Recommendations other than the ITU-T ISDN interface Recommendation (e.g. the V- or X-series interface Recommendations) or has interfaces not included in ITU-T Recommendation.
- TEI - Terminal Endpoint Identifier, is used to identify a specific connection endpoint within a service access point.
- TA - Terminal Adapter, is used to allow a TE2 terminal to be served by an ISDN user-network interface. It includes functions broadly belonging to layer 1 and higher layers of the ITU-T Recommendation X.200 reference model.
- ET - Exchange Termination, is used to indicate exchange terminating functional group which includes at least the layer 2 (Q.920/Q921) and layer 3 (Q.930/Q.931) network side functions.

## 6. SUMMARY OF CAPABILITIES

### 6.1 SERVICE FEATURE CHARACTERISTICS

- 6.1.1 Circuit mode bearer service is supported over the S/T reference point of the basic rate access interface:

Circuit mode: 64 kbps, 8 kHz structured, on demand

- 3.1 kHz audio
- speech
- unrestricted digital

- 6.1.2 Rate Adaptation is not performed in the network.

## 6.2 SUMMARY OF CAPABILITIES FOR LAYER 1

- 6.2.1 Both point-to-point and point-to-multipoint configurations are supported.
- 6.2.2 Interface connector and contact assignments shall conform to ISO 8877 standard.
- 6.2.3 Layer 1 will provide the signalling capabilities and the necessary procedures to enable TEs and NTs to be activated and deactivated where required.
- 6.2.4 Either activating/deactivating NT or non-activating/non-deactivating NT will be used at the discretion of the FTNS operator depending on network conditions.

## 6.3 SUMMARY OF CAPABILITIES FOR LAYER 2

- 6.3.1 Both acknowledged and unacknowledged operations are supported.
- 6.3.2 Acknowledged operation is only applicable to point-to-point information transfer.
- 6.3.3 Data link layer monitor function is supported in the network side.
- 6.3.4 On-demand data link connection is supported.
- 6.3.5 Layer 2 entity shall request the activation and deactivation of the physical layer connection.
- 6.3.6 Both automatic and non-automatic TEI assignment procedures are supported.
- 6.3.7 Default parameter values:-

SAPI	=	0 for signalling
N200	=	3
N201	=	260 octets
N202	=	3
T200	=	1 second
T201	=	T200
T202	=	2 seconds
T203	=	10 seconds
k	=	1 for a service access point supporting basic rate access signalling

#### 6.4 SUMMARY OF CAPABILITIES FOR LAYER 3

6.4.1 For circuit switched connection, both overlap and enbloc sending modes are supported.

6.4.2 For circuit switched connection, only enbloc receiving mode is supported.

6.4.3 The following messages are supported:-

ALERTING	SUSPEND
CALL PROCEEDING	SUSPEND ACKNOWLEDGE
CONNECT	SUSPEND REJECT
CONNECT ACKNOWLEDGE	DISCONNECT
PROGRESS	RELEASE
SETUP	RELEASE COMPLETE
SETUP ACKNOWLEDGE	INFORMATION
RESUME	NOTIFY
RESUME ACKNOWLEDGE	STATUS
RESUME REJECT	STATUS ENQUIRY

6.4.4 The following information elements are supported:-

Sending Complete	Keypad Facility
Bearer Capability	Signal
Cause	Feature Activation
Call Identity	Feature Indication
Call State	Calling Party Number
Channel Identification	Called Party Number
Progress Indicator	Called Party Number
Notification Indicator	Low Layer Compatibility
Display	High Layer Compatibility

6.4.5 The following timers in the network side are supported:-

T301	T308
T302	T309
T303	T310
T305	T312
T307	T322

## 7. CHARACTERISTICS OF DIGITAL PHONES AND VOICE PORTS

### 7.1 DIGITAL PHONES

Digital phones when connected to the ISDN are recommended to follow ITU-T Recommendation P.310.

Short-term objective of loudness rating:

- Send Loudness Rating (SLR): within the range of 5 to 11 dB
- Receive Loudness Rating (RLR): within the range of -1 to 5 dB

Long-term objective of loudness rating:

- Send Loudness Rating (SLR): 8 dB
- Receive Loudness Rating (RLR): 2 dB

Supervisory Tones Recommendation:

Please refer to the HKTA 2201 “General Technical Characteristics of the Fixed Telecommunications Networks in Hong Kong”.

### 7.2 ANALOGUE INTERFACE

Analogue Interface when provided are highly recommended to support the supervisory tones as specified in the HKTA 2201.

## 8. PROPAGATION DELAY

Because of various types of connection media being used in the FTNS operator's network and international network, propagation delay varies significantly depending on media used, e.g. satellite, cable, etc. In order to adapt to delay caused by different media, CPE should be able to perform handshaking for propagation delay up to 800 ms. Capability of the CPE to handle extra delay which could occur in long distance calls will be desirable.

## 9. REFERENCES DOCUMENTS

- [1] ITU-T Recommendation I.430 Basic user-network interface layer 1 specification
- [2] ITU-T Recommendation Q.920 (I.440) ISDN user-network interface data link layer - General aspects
- [3] ITU-T Recommendation Q.921 (I.441) ISDN user-network interface data link layer specification
- [4] ITU-T Recommendation Q.930 (I.450) ISDN user-network interface layer 3 - General aspects
- [5] ITU-T Recommendation Q.931 (I.451) ISDN user-network interface layer 3 specification for basic call control
- [6] ITU-T Recommendation I.23X - Bearer services
- [7] ITU-T Recommendation I.24X - Teleservices
- [8] ITU-T Recommendation I.320 - ISDN protocol reference model
- [9] ITU-T Recommendation I.33X - Numbering, addressing and routing
- [10] ITU-T Recommendation I.41X - ISDN user-network interfaces

- [11] ITU-T Recommendation G.117 - Transmission aspects of unbalance about earth (definitions and methods)
- [12] ITU-T Recommendation G.711 - Pulse code modulation (PCM) of voice frequencies
- [13] ITU-T Recommendation G.960 - Digital section for ISDN Basic Rate Access
- [14] ITU-T Recommendation G.961 - Digital transmission system on metallic local lines for ISDN Basic Rate Access
- [15] ITU-T Recommendation X.21 - Interface between data terminal equipment (DTE) and data circuit terminating equipment (DCE) for synchronous operation on public data networks
- [16] ITU-T Recommendation X.121 - International numbering plan for public data networks
- [17] ITU-T Recommendation X.211 - Information Technology - Open System Interconnection - Physical service definition
- [18] ITU-T Recommendation E.164 - The international public telecommunication numbering plan
- [19] ITU-T Recommendation F.69 - Plan for telex destination codes
- [20] ITU-T Recommendation T.62 - Control procedures for Teletex and Group 4 facsimile services
- [21] ISO 3309 Data communication - High-level data link control procedures - Frame structure
- [22] ISO 4335 Data communication - High-level data link control procedures - Consolidation of elements of procedures
- [23] ITU-T Recommendation P.310 - Transmission Characteristics for Telephone Band (300-3400 Hz) Digital Telephones

SECTION II  
PART A

ISDN BASIC RATE USER-NETWORK INTERFACE  
LAYER 1 SPECIFICATION

**Compliance With ITU-T Recommendation I.430**

Basic Rate Access

Item No.	Compliance						Descriptions / Notes
	A	B	C	D	E	F	
1.						O	<u>GENERAL</u>
2.							<u>SERVICE CHARACTERISTICS</u>
2.1	O						<u>Services Required from the Physical Medium</u>
2.2	O						<u>Service Provided To Layer 2</u>
2.2.1	O						<u>Transmission capability</u>
2.2.2	O						<u>Activation/deactivation</u>
2.2.3	O						<u>D-channel access</u>
2.2.4	O						<u>Maintenance</u>
2.2.5	O						<u>Status Indication</u>
2.3	O						<u>Primitives between Layer 1 and Other Entities</u>
3.						O	<u>MODES OF OPERATION</u>
3.1	O						<u>Point-To-Point Operation</u>
3.2	O						<u>Point-To-Multipoint Operation</u>
4.						O	<u>TYPES OF WIRING CONFIGURATION</u>
4.1			O				<u>Point-To-Point Configuration</u> 1. The point-to-point wiring configuration indicated in Annex A of ITU-T Recommendation I.430 is supported. 2. NT1 star wiring configuration is not supported.
4.2			O				<u>Point-To-Multipoint Configuration</u> Short passive bus (with NT1 located at one end) and extended passive bus wiring configurations indicated in Annex A of ITU-T Recommendation I.430 are supported.
4.3		O					<u>Wiring Polarity Integrity</u> The wires of the optional pairs for powering are not used.
4.4		O					<u>Location of the Interfaces</u> The wiring in the user premises is considered to be one continuous cable run with jack for the TE and NT attached directly to the cable or using stub less than 1 meter in length
4.5	O						<u>NT and TE Associated Wiring</u>

A : Complied with ITU-T

B : Complied with ITU-T with additional notes

C : Partially complied with ITU-T

D : Not supported

E : Under study

F : Descriptive text only

A/1

Item No.	Compliance						Descriptions / Notes
	A	B	C	D	E	F	
5.						O	<u>FUNCTIONAL CHARACTERISTICS</u>
5.1							<u>Interface Functions</u>
5.1.1	O						<u>B-channel</u>
5.1.2	O						<u>Bit timing</u>
5.1.3	O						<u>Octet timing</u>
5.1.4	O						<u>Frame alignment</u>
5.1.5	O						<u>D-channel</u>
5.1.6	O						<u>D-channel access procedure</u>
5.1.7				O			<u>Power feeding</u> Power feeding from NT to TE is not supported.
5.1.8		O					<u>Deactivation</u> 1. TEs are not power fed across the interface from power source. 2. NTs are not remotely power fed.
5.1.9	O						<u>Activation</u>
5.2	O						<u>Interchange Circuits</u>
5.3	O						<u>Connected/disconnected Indication</u>
5.3.1				O			<u>TEs powered across the interface</u> Power feeding from NT to TE is not supported.
5.3.2			O				<u>TEs not powered across the interface</u> TEs shall use the presence/absence of local power to establish the connection status.
5.3.3			O				<u>Indication of connection status</u> TEs shall inform the management entity using : 1. <u>MPH-INFORMATION INDICATION (connected)</u> When presence of local power is detected. 2. <u>MPH-INFORMATION INDICATION (disconnected)</u> When loss of local power is detected.
5.4	O						<u>Frame Structure</u>
5.4.1	O						<u>Bit rate</u>
5.4.2	O						<u>Binary organisation of the frame</u>
5.4.2.1	O						<u>TE to NT</u>
5.4.2.2	O						<u>NT to TE</u>
5.4.2.3	O						<u>Relative bit positions</u>
5.5	O						<u>Line Code</u>
5.6	O						<u>Timing Considerations</u>

Item No.	Compliance						Descriptions / Notes
	A	B	C	D	E	F	
6.							<u>INTERFACE PROCEDURES</u>
6.1	O						<u>D-channel Access Procedure :</u>
6.1.1		O					<u>Interframe (layer 2) time fill</u> The interframe time fill in the NT-to TE direction is HDLC flag.
6.1.2	O						<u>D-echo channel</u>
6.1.3	O						<u>D channel monitoring</u>
6.1.4	O						<u>Priority mechanism</u>
6.1.5	O						<u>Collision detection</u>
6.1.6		O					<u>Priority system</u> The priority system is implemented as described in Annex B of ITU-T Recommendation I.430.
6.2							<u>Activation/Deactivation</u>
6.2.1							<u>Definitions</u>
6.2.1.1	O						<u>TE states</u> State F1 is entered when local power is not present.
6.2.1.2	O						<u>NT states</u>
6.2.1.3	O						<u>Activate primitives</u>
6.2.1.4	O						<u>Deactivate primitives</u>
6.2.1.5	O						<u>Management primitives</u>
6.2.1.6	O						<u>Valid primitive sequences</u>
6.2.2		O					<u>Signals</u> The F <sub>A</sub> bits and the M bits from NT will provide Q-bit pattern designation during transmission of INFO 2 and INFO 4.
6.2.3							<u>Activation/deactivation procedure for TEs</u>
6.2.3.1	O						<u>General TE procedure</u>
6.2.3.2		O					<u>Specification of the procedure</u> Only those for locally powered TEs are described

Item No.	Compliance						Descriptions / Notes
	A	B	C	D	E	F	
6.2.4							<u>Activation/deactivation for NTs</u>
6.2.4.1	O						<u>Activating/deactivating NTs</u>
6.2.4.2		O					<u>Non-activating/non-deactivating NTs</u>
6.2.5		O					States G1 (deactivated), G4 (pending deactivation) and timers 1 and 2 exist under abnormal condition. <u>Timer values</u> For activating/deactivating NTs, timer T1 = 500 ms and timer T2 = 100 ms. For non-activating/non-deactivating NTs, timer T1 = 15s and timer T2 = 95 ms.
6.2.6							<u>Activation times</u>
6.2.6.1	O						<u>TE activation times</u>
6.2.6.2	O						<u>NT activation times</u>
6.2.7		O					<u>Deactivation times</u> A TE shall respond to the receipt of INFO 0 by initiating the transmission of INFO 0 within 95 ms.
6.3	O						<u>Frame Alignment Procedures</u>
6.3.1	O						<u>Frame alignment procedure in the direction NT to TE</u>
6.3.1.1	O						<u>Loss of frame alignment</u>
6.3.1.2	O						<u>Frame alignment</u>
6.3.2	O						<u>Frame alignment in the direction TE to NT</u>
6.3.2.1	O						<u>Loss of frame alignment</u>
6.3.2.2	O						<u>Frame alignment</u>
6.3.3	O						<u>Multi-framing</u>
6.3.4	O						<u>S-bit channel structuring algorithm</u>
6.4	O						<u>Idle Channel Code on the B Channels</u>
7.		O					<u>LAYER 1 MAINTENANCE</u>  Loopback 2 described in Appendix I of ITU-T Recommendation I.430 is supported. In addition, B1 and B2 channel loopbacks by NT are also supported.

Item No.	Compliance						Descriptions / Notes
	A	B	C	D	E	F	
8.							<u>ELECTRICAL CHARACTERISTICS</u>
8.1	O						<u>Bit Rate</u>
8.2							<u>Jitter and Bit-Phase Relationship between TE Input and Output</u>
8.2.1		O					<u>Test configurations</u> The test configurations described in Annex D of ITU-T Recommendation I.430 are used.
8.2.2	O						<u>Timing extraction jitter</u>
8.2.3	O						<u>Total phase deviation, input to output</u>
8.3	O						<u>NT Jitter Characteristics</u>
8.4	O						<u>Termination of the Line</u>
8.5							<u>Transmitter Output Characteristics</u>
8.5.1	O						<u>Transmitter output impedance</u>
8.5.1.1	O						<u>NT transmitter output impedance</u>
8.5.1.2	O						<u>TE transmitter output impedance</u>
8.5.2	O						<u>Test load impedance</u>
8.5.3							<u>Pulse shape and amplitude (binary ZERO)</u>
8.5.3.1	O						<u>Pulse shape</u>
8.5.3.2	O						<u>Nominal pulse amplitude</u>
8.5.4	O						<u>Pulse Unbalance</u>
8.5.5	O						<u>Voltage on other test loads (TE only)</u>
8.5.5.1	O						<u>400-ohm load</u>
8.5.5.2	O						<u>5.6-ohm load</u>
8.5.6	O						<u>Unbalance about earth</u>
8.5.6.1	O						<u>Longitudinal conversion loss</u>
8.5.6.2	O						<u>Output signal balance</u>
8.6							<u>Receiver Input Characteristics</u>
8.6.1							<u>Receiver input impedance</u>
8.6.1.1	O						<u>TE receiver input impedance</u>
8.6.1.2	O						<u>NT receiver input impedance</u>

**Compliance With ITU-T Recommendation I.430**

Item No.	Compliance						Descriptions / Notes
	A	B	C	D	E	F	
8.6.2	O						<u>Receiver sensitivity - noise and distortion immunity</u>
8.6.2.1	O						<u>TEs</u>
8.6.2.2	O						<u>NTs for short passive bus (fixed timing)</u>
8.6.2.3	O						<u>NTs for both point-to-point and short passive bus configurations (adaptive timing)</u>
8.6.2.4		O					<u>NTs for extended passive bus wiring configurations</u> The maximum cable loss is of 3.8 dB at 96 kHz.
8.6.2.5				O			<u>NTs for point-to-point configurations only</u> Such kind of NT is not provided.
8.6.3	O						<u>NT receiver input delay characteristics</u>
8.6.3.1	O						<u>NT for short passive bus</u>
8.6.3.2	O						<u>NTs for both point-to-point and passive bus</u>
8.6.3.3	O						<u>NTs for extended passive bus</u>
8.6.3.4				O			<u>NTs for point-to-point only</u> Such kind of NT is not provided.
8.6.4	O						<u>Unbalance about earth</u>
8.7	O						<u>Isolation from External Voltages</u>
8.8	O						<u>Interconnecting Media Characteristics</u>
8.9	O						<u>Standard ISDN Basic Access TE Cord</u>

**Compliance With ITU-T Recommendation I.430**

Basic Rate Access

Item No.	Compliance						Descriptions / Notes
	A	B	C	D	E	F	
9.							<u>POWER FEEDING</u>
9.1			O				<u>Reference Configuration</u> Power source 1 & 2 are not supported..
9.1.1			O				<u>Functions specified at the across leads</u> Power source 1 & 2 are not supported.
9.1.2				O			<u>Provision of power sources and sinks</u> Power source 1 & 2 are not supported.
9.2				O			<u>Power available from NT</u> Power source 1 & 2 are not supported.
9.3				O			<u>Power available at TE</u> Power source 1 & 2 are not supported.
9.4				O			<u>Current Transient</u> Not applicable as power feeding from NT is not supported..
9.5				O			<u>Power Source 1 Consumption</u> Power source 1 is not supported.
9.6	O						<u>Galvanic Isolation</u>
10.			O				<u>INTERFACE CONNECTOR AND CONTACT ASSIGNMENTS</u> Power source 2 is not supported.

A : Complied with ITU-T

B : Complied with ITU-T with additional notes

C : Partially complied with ITU-T

D : Not supported

E : Under study

F : Descriptive text only

SECTION II  
PART B

ISDN USER-NETWORK INTERFACE  
DATA LINK LAYER GENERAL ASPECTS  
(BASIC RATE ACCESS)

**Compliance With ITU-T Recommendation I.440 (Q.920)**

Basic Rate Access

Item No.	Compliance						Descriptions / Notes
	A	B	C	D	E	F	
1.						O	<u>GENERAL</u>
2.						O	<u>CONCEPTS AND TERMINOLOGY</u>
3.							<u>OVERVIEW DESCRIPTION OF LAPD FUNCTIONS &amp; PROCEDURES</u>
3.1						O	<u>General</u>
3.2	O						<u>Unacknowledged Operation</u>
3.3	O						<u>Acknowledged Operation</u>
3.4							<u>Establishment of Information Transfer Modes</u>
3.4.1	O						<u>Data link connection identification</u>
3.4.2	O						<u>Data link states</u>
3.4.3	O						<u>TEI administration</u>
3.4.4	O						<u>Establishment of multiple frame operation</u>
4.							<u>SERVICE CHARACTERISTICS.</u>
4.1						O	<u>General</u>
4.2	O						<u>Services Provided to Layer 3</u>
4.2.1	O						<u>Unacknowledged information transfer service</u>
4.2.2	O						<u>Acknowledged information transfer service</u>
4.3	O						<u>Services Provided to Layer Management</u>
4.4		O					<u>Administrative Services</u> Passing of data link connection parameter (through XID) is not supported.
4.5							<u>Model of the Data Link Service</u>
4.5.1	O						<u>General</u>
4.5.2							<u>Data link layer representation as seen by layer 3</u>
4.5.2.1	O						<u>Data link connection endpoint states</u>
4.5.2.2	O						<u>Broadcast data link layer connection services</u>
4.5.2.3	O						<u>Point-to-point data link connection endpoint services</u>
4.5.2.4	O						<u>Sequences of primitives at one point-to-point data link connection endpoint</u>
4.6	O						<u>Services Required from the Physical Layer</u>
5.		O					<u>DATA LINK LAYER - MANAGEMENT STRUCTURE</u> The functions of parameter initialization performed by automatic negotiation of Connection Management Entity (CME) is not supported.
5.1	O						<u>Data Link Procedure</u>
5.2	O						<u>Multiplex Procedure</u>
5.3	O						<u>Structure of the Data Link Procedure</u>

A : Complied with ITU-T

B : Complied with ITU-T with additional notes

C : Partially complied with ITU-T

D : Not supported

E : Under study

F : Descriptive text only

B/1

SECTION II  
PART C

ISDN USER-NETWORK INTERFACE  
DATA LINK LAYER SPECIFICATION  
(BASIC RATE ACCESS)

**Compliance With ITU-T Recommendation I.441 (Q.921)**

Basic Rate Access

Item No.	Compliance						Descriptions / Notes
	A	B	C	D	E	F	
1.						O	<u>GENERAL</u>
2.							<u>FRAME STRUCTURE FOR PEER-TO-PEER COMMUNICATION</u>
2.1	O						<u>General</u>
2.2	O						<u>Flag Sequence</u>
2.3		O					<u>Address Field</u> Single octet address field for LAPB operation is not supported.
2.4	O						<u>Control Field</u>
2.5	O						<u>Information Field</u>
2.6	O						<u>Transparency</u>
2.7	O						<u>Frame Check Sequence (FCS) Field</u>
2.8	O						<u>Format Convention</u>
2.9	O						<u>Invalid Frames</u>
2.10	O						<u>Frame Abort</u>
3.							<u>ELEMENTS OF PROCEDURES AND FORMATS OF FIELDS FOR DATA LINK LAYER PEER-TO-PEER COMMUNICATION</u>
3.1	O						<u>General</u>
3.2	O						<u>Address Field Format</u>
3.3							<u>Address Field Variables</u>
3.3.1	O						<u>Address field extension bit (EA)</u>
3.3.2	O						<u>Command/response field bit (C/R)</u>
3.3.3			O				<u>Service access point identifier (SAPI)</u> Only SAPI = 0 and 63 shall be assigned for network-side and user-side.
3.3.4	O						<u>Terminal endpoint identifier (TEI)</u>
3.3.4.1	O						<u>TEI for broadcast data link connection</u>
3.3.4.2	O						<u>TEI for point-point data link connection</u>
3.4							<u>Control Field Formats</u>
3.4.1	O						<u>Information transfer (I) format</u>
3.4.2	O						<u>Supervisory (S) format</u>
3.4.3	O						<u>Unnumbered (U) format</u>

A : Complied with ITU-T

B : Complied with ITU-T with additional notes

C : Partially complied with ITU-T

D : Not supported

E : Under study

F : Descriptive text only

C/1

Item No.	Compliance						Descriptions / Notes
	A	B	C	D	E	F	
3.5						O	<u>Control Field Parameters and Associated State Variables</u>
3.5.1	O						<u>Poll/Final (P/F) bit</u>
3.5.2							<u>Multiple frame operation - variables and sequence numbers</u>
3.5.2.1	O						<u>Modules</u>
3.5.2.2	O						<u>Send state variable V(S)</u>
3.5.2.3	O						<u>Acknowledge state variable V(A)</u>
3.5.2.4	O						<u>Send sequence number N(S)</u>
3.5.2.5	O						<u>Receive state variable V(R)</u>
3.5.2.6	O						<u>Receive sequence number N(R)</u>
3.5.3	O						<u>Unacknowledged operation - variables and parameters</u>
3.6							<u>Frame Types</u>
3.6.1	O						<u>Commands and responses</u>
3.6.2	O						<u>Information (I) command</u>
3.6.3	O						<u>Set asynchronous balanced mode extended (SABME) command</u>
3.6.4	O						<u>Disconnect (DISC) command</u>
3.6.5	O						<u>Unnumbered information (UI) command</u>
3.6.6	O						<u>Received ready (RR) command/response</u>
3.6.7		O					<u>Reject (REJ) command/response</u> The optional procedure for the retransmission of REJ response frame described in Appendix I of ITU-T Recommendation Q.921 is not supported.
3.6.8	O						<u>Received not ready (RNR) command/response</u>
3.6.9	O						<u>Unnumbered acknowledgement (UA) response</u>
3.6.10	O						<u>Disconnected mode (DM) response</u>
3.6.11	O						<u>Frame reject (FRMR) response</u>
3.6.12				O			<u>Exchange Identification (XID) Command/Response</u> It is not supported.

Item No.	Compliance						Descriptions / Notes
	A	B	C	D	E	F	
4.							<u>ELEMENTS FOR LAYER-TO-LAYER COMMUNICATION</u>
4.1						O	<u>General</u>
4.1.1						O	<u>Generic Names</u>
4.1.1.1	O						<u>DL-ESTABLISH</u>
4.1.1.2	O						<u>DL-RELEASE</u>
4.1.1.3	O						<u>DL-DATA</u>
4.1.1.4	O						<u>DL-UNIT DATA</u>
4.1.1.5	O						<u>MDL-ASSIGN</u>
4.1.1.6	O						<u>MDL-REMOVE</u>
4.1.1.7	O						<u>MDL-ERROR</u>
4.1.1.8	O						<u>MDL-UNIT DATA</u>
4.1.1.9				O			<u>MDL-XID</u> It is not supported.
4.1.1.10	O						<u>PH-DATA</u>
4.1.1.11	O						<u>PH-ACTIVATE</u>
4.1.1.12	O						<u>PH-DEACTIVATE</u>
4.1.1.13	O						<u>MPH-ACTIVATE</u>
4.1.1.14	O						<u>MPH-DEACTIVATE</u>
4.1.1.15		O					<u>MPH-INFORMATION</u> This primitive may exist at the user side management entity.
4.1.1.16			O				<u>MPH-ERROR</u> This primitive is used to indicate to layer management entity that an error has occurred.
4.1.2	O						<u>Primitive types</u>
4.1.2.1	O						<u>REQUEST</u>
4.1.2.2	O						<u>INDICATION</u>
4.1.2.3	O						<u>RESPONSE</u>
4.1.2.4	O						<u>CONFIRM</u>
4.1.3							<u>Parameter definition</u>
4.1.3.1	O						<u>Priority indicator</u>
4.1.3.2	O						<u>Message unit</u>
4.2							<u>Primitive Procedures</u>
4.2.1						O	<u>General</u>
4.2.2	O						<u>Layer 3 - Data Link Layer Interactions</u>

Item No.	Compliance						Descriptions / Notes
	A	B	C	D	E	F	
5.			O				<u>DEFINITION OF THE PEER-TO-PEER PROCEDURES OF THE DATA LINK LAYER</u> Connection Management entity information transfer (through XID) is not supported.
5.1							<u>Procedure for the Use of the P/F Bit</u>
5.1.1	O						<u>Unacknowledged information transfer</u>
5.1.2	O						<u>Acknowledged multiple frame information transfer</u>
5.2							<u>Procedures for Unacknowledged Information Transfer</u>
5.2.1						O	<u>General</u>
5.2.2	O						<u>Transmission of unacknowledged information</u>
5.2.3	O						<u>Receipt of unacknowledged information</u>
5.3							<u>Terminal Endpoint Identifier (TEI) Management Procedures</u>
5.3.1	O						<u>General</u>
5.3.2	O						<u>TEI assignment procedure</u>
5.3.2.1	O						<u>Expiry of timer T202</u>
5.3.3							<u>TEI check procedure</u>
5.3.3.1	O						<u>Use of the TEI check procedure</u>
5.3.3.2	O						<u>Operation of TEI check procedure</u>
5.3.4	O						<u>TEI removal procedure</u>
5.3.4.1	O						<u>Action taken by the data link layer entity receiving the MDL-REMOVE-REQUEST primitive</u>
5.3.4.2	O						<u>Conditions for TEI removal</u>
5.3.5							<u>TEI identity verify procedure</u>
5.3.5.1		O					<u>General</u> The TEI identify verify procedure is supported by the network and is optional for user equipment.
5.3.5.2	O						<u>Operation of the TEI identity verify procedure</u>
5.3.5.3	O						<u>Expiry of Timer T202</u>
5.3.6							<u>Formats and codes</u>
5.3.6.1	O						<u>General</u>
5.3.6.2	O						<u>Layer management entity identifier</u>
5.3.6.3	O						<u>Reference number (Rn)</u>
5.3.6.4	O						<u>Message type</u>
5.3.6.5	O						<u>Action indicator (Ai)</u>
5.4				O			<u>Automatic Negotiation of Data Link Layer Parameters</u> It is not supported.

Item No.	Compliance						Descriptions / Notes
	A	B	C	D	E	F	
5.5							<u>Procedures for Establishment and Release of Multiple Frame Operation</u>
5.5.1	O						<u>Establishment of multiple frame operation</u>
5.5.1.1	O						<u>General</u>
5.5.1.2		O					<u>Establishment procedures</u> Timer T203 is supported.
5.5.1.3	O						<u>Procedure on expiry of timer T200</u>
5.5.2	O						<u>Information transfer</u>
5.5.3							<u>Termination of multiple frame operation</u>
5.5.3.1	O						<u>General</u>
5.5.3.2	O						<u>Release procedure</u>
5.5.3.3	O						<u>Procedure on expiry of timer T200</u>
5.5.4	O						<u>TEI-assigned state</u>
5.5.5							<u>Collision of unnumbered commands and responses</u>
5.5.5.1	O						<u>Identical transmitted and received commands</u>
5.5.5.2	O						<u>Different transmitted and received commands</u>
5.5.6	O						<u>Unsolicited DM response and SABME or DISC command</u>
5.6						O	<u>Procedures for Information Transfer in Multiple Frame Operation</u>
5.6.1		O					<u>Transmitting I frames</u> When the network side is in the own receiver busy condition, it will still transmit I frames, provided that a peer receiver busy condition does not exist.
5.6.2	O						<u>Receiving I frames</u>
5.6.2.1	O						<u>P bit set to 1</u>
5.6.2.2	O						<u>P bit set to 0</u>
5.6.3							<u>Sending and receiving acknowledgments</u>
5.6.3.1	O						<u>Sending acknowledgements</u>
5.6.3.2	O						<u>Receiving acknowledgements</u>
5.6.4		O					<u>Receiving REJ frames</u> Timer T203 is supported.
5.6.5	O						<u>Receiving RNR frames</u>
5.6.6	O						<u>Data link layer own receiver busy condition</u>
5.6.7		O					<u>Waiting acknowledgment</u> In case of the value of the transmission count variable is less than N200, network will restart timer T200 and transmit an appropriate supervisory command with P bit set to 1.

Item No.	Compliance						Descriptions / Notes
	A	B	C	D	E	F	
5.7							<u>Re-establishment of Multiple Frame Operation</u>
5.7.1	O						<u>Criteria for re-establishment</u>
5.7.2	O						<u>Procedures</u>
5.8	O						<u>Exception Condition Reporting and Recovery</u>
5.8.1		O					<u>N(S) sequence error</u> The optional procedure for the retransmission of REJ response frame described in Appendix of ITU-T Recommendation Q.921 is not supported.
5.8.2	O						<u>N(R) sequence error</u>
5.8.3	O						<u>Timer recovery condition</u>
5.8.4	O						<u>Invalid frame condition</u>
5.8.5	O						<u>Frame rejection condition</u>
5.8.6	O						<u>Receipt of FRMR response frame</u>
5.8.7	O						<u>Unsolicited response frame</u>
5.8.8							<u>Multiple assignment of a TEI value</u>
5.9			O				<u>List of System Parameters</u> Negotiation of system parameters is not supported.
5.9.1		O					<u>Timer T200</u> The timer value is 1 second.
5.9.2	O						<u>Maximum number of retransmissions (N200)</u>
5.9.3	O						<u>Maximum number of octets in an information field (N201)</u>
5.9.4	O						<u>Maximum number of transmissions of the TEI Identity request message (N202)</u>
5.9.5			O				<u>Maximum number of outstanding I frames (k)</u> Only k = 1 is supported for an SAP supporting basic rate (16 kbit/s) signalling.
5.9.6	O						<u>Timer T201</u>
5.9.7	O						<u>Timer T202</u>
5.9.8	O						<u>Timer T203</u>
5.10							<u>Data Link Layer Monitoring Function</u>
5.10.1	O						<u>General</u>
5.10.2	O						<u>Data link layer supervision in the multiple-frame-established state</u> The implementation of procedure for data link layer resource supervision is optional in the user side.
5.10.3							<u>Connection verification procedures</u>
5.10.3.1	O						<u>Start timer T203</u>
5.10.3.2	O						<u>Stop timer T203</u>
5.10.3.3	O						<u>Expiry of timer T203</u>

SECTION II  
PART D

ISDN USER-NETWORK INTERFACE LAYER 3 GENERAL ASPECTS  
(BASIC RATE ACCESS)

**Compliance With ITU-T Recommendation I.450 (Q.930)**

Basic Rate Access

Item No.	Compliance						Descriptions / Notes
	A	B	C	D	E	F	
1.						O	<u>GENERAL</u>
1.1							<u>Introduction</u>
1.2		O					<u>Connection Control by the User of an ISDN</u> Packet-switched connection is not supported.
1.3	O						<u>Services Provided by the Data Link Layer</u>
1.4				O			<u>Symmetry of the Layer 3 Protocol</u> Symmetry of the layer 3 protocol is not within the scope of this specification.
2.							<u>STRUCTURE OF LAYER 3</u>
2.1			O				<u>Categories of Functions</u> Message segmenting/reassembly is not supported.
2.2			O				<u>Layer 3 Functions</u> Packet-switched connections are not supported. The following functions are performed at network side of the user-network interface and may also applicable at user side of the interface. a) processing of primitives for communicating with the data link layer; b) generation and interpretation of layer 3 messages for peer-level communication; c) administration of timers and logical entities used in the call control procedure; d) administration of access resources including B-channels; e) checking to ensure that services provided are consistent with user requirements (e.g. as expressed by bearer capability, addresses). Note that the checking of lower and higher layers compatibility is only applicable at the user side. General function shall also be performed by layer 3: a) routing and relaying (optional); b) network connection control (network side only); c) conveying user-to-network and network-to-user information (not supported); d) network connection multiplexing; (network side only); e) segmenting and reassembly (not supported); f) error detection; g) error recovery; h) sequencing; i) congestion control (user data flow control is not supported); and j) restart (not supported).

A : Complied with ITU-T

B : Complied with ITU-T with additional notes

C : Partially complied with ITU-T

D : Not supported

E : Under study

F : Descriptive text only

D/1

**Compliance With ITU-T Recommendation I.450 (Q.930)**

Basic Rate Access

Item No.	Compliance						Descriptions / Notes
	A	B	C	D	E	F	
2.2.1	O						<u>Routing and relaying</u>
2.2.2	O						<u>Network connection control</u>
2.2.3				O			<u>Conveying user information</u> It is not supported.
2.2.4	O						<u>Network connection multiplexing</u>
2.2.5				O			<u>Segmenting and reassembly</u> It is not supported.
2.2.6	O						<u>Error detection</u>
2.2.7	O						<u>Error recovery</u>
2.2.8			O				<u>Sequencing</u> Layer 3 only ensures the delivery of information in the same sequence as submitted by the user.
2.2.9			O				<u>Congestion control and user data flow control</u> 1. Rejection or unsuccessful indication for connection establish requests to control congestion within a network will not be indicated by layer 3. Congestion condition will be handled by the switching system. (Congestion Control messages are not supported) 2. Flow control for the user-to-user signalling message is not supported.
2.2.10				O			<u>Restart</u> It is not supported.
3.						O	<u>STRUCTURE OF LAYER 3 RECOMMENDATIONS</u>
4.							<u>INTERFACE BETWEEN LAYER 3 AND THE ADJACENT LAYERS</u>
4.1						O	<u>Overview of the Interfaces</u>
4.2	O						<u>Interface between Layer 3 and Data Link Layer</u>
4.3					O		<u>Interface between Layer 3 and Upper Layer</u> It is left for ITU-T further study.

A : Complied with ITU-T

B : Complied with ITU-T with additional notes

C : Partially complied with ITU-T

D : Not supported

E : Under study

F : Descriptive text only

SECTION II  
PART E

ISDN USER-NETWORK INTERFACE  
LAYER 3 SPECIFICATION FOR BASIC CALL CONTROL  
(BASIC RATE ACCESS)

**Compliance With ITU-T Recommendation I.451 (Q.931)**

Basic Rate Access

Item No.	Compliance						Descriptions / Notes
	A	B	C	D	E	F	
1.						O	<u>GENERAL</u>
1.1				O			<u>Scope of the Recommendation</u> Packet-switched connection is not supported.
1.2	O						<u>Application to Interface Structure</u>
2.				O			<u>OVERVIEW OF CALL CONTROL</u> Packet-switched connection is not supported.
2.1	O						<u>Circuit Switched Calls</u> Symmetric signalling protocols describe in Q.931 are not within the scope of this specification.
2.1.1		O					<u>Call states at the user side of the interface</u> The call states under this section are subject to user implementation.
2.1.1.1		O					<u>Null (U0)</u>
2.1.1.2		O					<u>Call Initiated (U1)</u>
2.1.1.3		O					<u>Overlap Sending (U2)</u>
2.1.1.4		O					<u>Outgoing Call Proceeding (U3)</u>
2.1.1.5		O					<u>Call Delivered (U4)</u>
2.1.1.6		O					<u>Call Present (U6)</u>
2.1.1.7		O					<u>Call Received (U7)</u>
2.1.1.8		O					<u>Connect Request (U8)</u>
2.1.1.9		O					<u>Incoming Call Proceeding (U9)</u>
2.1.1.10		O					<u>Active (U10)</u>
2.1.1.11		O					<u>Disconnect Request (U11)</u>
2.1.1.12		O					<u>Disconnect Indication (U12)</u>
2.1.1.13		O					<u>Suspend Request (U15)</u>
2.1.1.14		O					<u>Resume Request (U17)</u>
2.1.1.15		O					<u>Release Request (U19)</u>
2.1.1.16				O			<u>Overlap Receiving (U25)</u> This state is not recommended to exist on the user side.
2.1.2	O						<u>Network Call States</u>
2.1.2.1	O						<u>Null (N0)</u>
2.1.2.2	O						<u>Call Initiated (N1)</u>
2.1.2.3	O						<u>Overlap Sending (N2)</u>
2.1.2.4	O						<u>Outgoing Call Proceeding (N3)</u>

A : Complied with ITU-T

B : Complied with ITU-T with additional notes

C : Partially complied with ITU-T

D : Not supported

E : Under study

F : Descriptive text only

E/1

**Compliance With ITU-T Recommendation I.451 (Q.931)**

Basic Rate Access

Item No.	Compliance						Descriptions / Notes
	A	B	C	D	E	F	
2.1.2.5	O						<u>Call Delivered (N4)</u>
2.1.2.6	O						<u>Call Present (N6)</u>
2.1.2.7	O						<u>Call Received (N7)</u>
2.1.2.8	O						<u>Connect Request (N8)</u>
2.1.2.9	O						<u>Incoming Call Proceeding (N9)</u>
2.1.2.10	O						<u>Active (N10)</u>
2.1.2.11	O						<u>Disconnect Request (N11)</u>
2.1.2.12	O						<u>Disconnect Indication (N12)</u>
2.1.2.13	O						<u>Suspend Request (N15)</u>
2.1.2.14	O						<u>Resume Request (N17)</u>
2.1.2.15	O						<u>Release Request (N19)</u>
2.1.2.16	O						<u>Call Abort (N22)</u>
2.1.2.17				O			<u>Overlap Receiving (N25)</u> It is not supported.
2.2				O			<u>Packet Mode Access Connections</u> It is not supported.
2.3				O			<u>Temporary Signalling Connections</u> It is not supported.
2.4				O			<u>States Associated with the Global Call Reference</u> It is not supported

A : Complied with ITU-T

B : Complied with ITU-T with additional notes

C : Partially complied with ITU-T

D : Not supported

E : Under study

F : Descriptive text only

Item No.	Compliance						Descriptions / Notes
	A	B	C	D	E	F	
3. 3.1			O			O	<p><u>MESSAGE FUNCTIONAL DEFINITIONS AND CONTENT</u>  <u>Messages for Circuit Mode Connection Control</u>                      Congestion Control, Facility and User Information messages are not supported.                      For those messages supported:</p> <ol style="list-style-type: none"> <li>1. The length of Call Reference information element is 2 octets.</li> <li>2. The length of Channel Identification information element is 3 octets.</li> <li>3. The length of Display information element is 2 to 34 octets.</li> <li>4. The length of Called party number is from 2 to 22 octets.</li> <li>5. The Calling party number in the network to user direction is supported.</li> <li>6. The following information elements are not supported:                             <ul style="list-style-type: none"> <li>- Shift</li> <li>- More data</li> <li>- Congestion level</li> <li>- Repeat indicator</li> <li>- Segmented message</li> <li>- Facility</li> <li>- Network-specific facilities</li> <li>- Date/Time</li> <li>- Switchhook</li> <li>- Information Rate</li> <li>- End-to-end transit delay</li> <li>- Transit delay selection and indication</li> <li>- Calling party subaddress</li> <li>- Called party subaddress</li> <li>- Packet layer binary parameters</li> <li>- Packet layer window size</li> <li>- Packet size</li> <li>- Redirection number</li> <li>- Transit network selection</li> <li>- restart indicator</li> <li>- User-user</li> <li>- Escape for extension</li> </ul> </li> </ol>

**Compliance With ITU-T Recommendation I.451 (Q.931)**

Item No.	Compliance						Descriptions / Notes
	A	B	C	D	E	F	
3.1.1			O				<u>Alerting</u> 1. The Display, Signal, Feature activation, and Feature indication information elements in this message are not supported. 2. The Channel identification information element in this message is supported
3.1.2			O				<u>Call Proceeding</u> The Display information element in this message is not supported.
3.1.3				O			<u>Congestion Control</u> It is not supported.
3.1.4			O				<u>Connect</u> 1. The Facility, Signal, Switchhook, Feature activation, and Feature indication information elements in this message are not supported. 2. The Channel identification information element in this message is supported only in the user-to-network direction. 3. The Low layer compatibility information element can optionally be included by user and the network will transport to the calling user.
3.1.5			O				<u>Connect Acknowledge</u> 1. The Channel identification, Display and Signal information elements in this message are not supported. 2. The support of this message in the user-to-network direction is optional.
3.1.6			O				<u>Disconnect</u> The Facility, Progress indicator, Signal, and Feature indication and User-user information elements in this message are not supported.
3.1.7				O			<u>Facility</u> It is not supported.
3.1.8			O				<u>Information</u> 1. The Signal information element in this message is not supported. 2. Called party number information element in this message is supported only in user-to-network direction. 3. Information request information element may be used for service control procedures. 4. Sending complete information element is in network to user direction only.
3.1.9			O				<u>Notify</u> The Bearer capability and Display information elements in this message are not supported.
3.1.10			O				<u>Progress</u> The inclusion of Cause and Display information elements in this message are not supported.
3.1.11			O				<u>Release</u> The Display, Signal and Feature indication information elements in this message are not supported.
3.1.12			O				<u>Release Complete</u> The Display, Signal and Feature indication information elements in this message are not supported.
3.1.13		O					<u>Resume</u> Supported but NOTIFY message to the other user is not guarantee.

Item No.	Compliance						Descriptions / Notes
	A	B	C	D	E	F	
3.1.14			O				<u>Resume Acknowledge</u> The Display information element in this message is not supported.
3.1.15			O				<u>Resume Reject</u> The Display information element in this message is not supported.
3.1.16			O				<u>Setup</u> 1. The Display, Feature activation and Feature indication information elements in this message are not supported. 2. The length of Keypad facility information element is 2 to 32 octets.
3.1.17			O				<u>Setup Acknowledge</u> 1. The Display and Signal information element in this message are not supported. 2. This message is supported only in network-to-user direction.
3.1.18			O				<u>Status</u> The Display information element in this message is not supported.
3.1.19			O				<u>Status Enquiry</u> The Display information element in this message is not supported.
3.1.20		O					<u>Suspend</u> Supported but NOTIFY message to the other user is not guarantee
3.1.21			O				<u>Suspend Acknowledge</u> The Display information element in this message is not supported.
3.1.22			O				<u>Suspend Reject</u> The Display information element in this message is not supported.
3.1.23				O			<u>User Information</u> It is not supported.
3.2				O			<u>Messages for Packet Mode Access Connection Control</u> They are not supported.
3.3				O			<u>Messages for User-to-user Signalling not Associated with Circuit Switched Calls</u> They are not supported.
3.4				O			<u>Messages used with the Global Call Reference</u> They are not supported.

Item No.	Compliance						Descriptions / Notes
	A	B	C	D	E	F	
4.						O	<u>GENERAL MESSAGE FORMAT AND INFORMATION ELEMENTS CODING</u>
4.1	O						<u>Overview</u>
4.2			O				<u>Protocol Discriminator</u> Only the coding "00001000" for Q.931 user-network call control messages is supported.
4.3			O				<u>Call Reference</u> 1. The call reference value is of one octet long.
4.4			O				2. Global call reference and dummy call reference are not supported
4.5							<u>Message Type</u> Segment, Congestion control, Facility, Restart, Restart acknowledge and User information messages are not supported.
4.5.1			O				<u>Other Information Elements</u> <u>Coding rules</u> The following information elements will be supported : <ul style="list-style-type: none"> <li>- Sending Complete</li> <li>- Bearer Capability</li> <li>- Cause</li> <li>- Call Identity</li> <li>- Call State</li> <li>- Channel Identification</li> <li>- Progress Indicator</li> <li>- Notification Indicator</li> <li>- Display</li> <li>- Keypad Facility</li> <li>- Information Request</li> <li>- Signal</li> <li>- Feature Activation</li> <li>- Feature Indication</li> <li>- Calling Party Number</li> <li>- Called Party Number</li> <li>- Low Layer Compatibility</li> <li>- High Layer Compatibility</li> </ul> The others are not supported. Note that network will not guarantee the end-to-end transport transparency of information elements between calling and called user side.

Item No.	Compliance						Descriptions / Notes
	A	B	C	D	E	F	
4.5.2			O				<u>Extensions of codesets</u> Only Codeset 0 is supported.
4.5.3			O				<u>Locking shift procedure</u> Only Codeset 0 is supported.
4.5.4			O				<u>Non-locking shift procedure</u> Only Codeset 0 is supported.
4.5.5			O				<u>Bearer capability</u> The following coding for octets 3 to 5 are supported : <ol style="list-style-type: none"> <li>1. <u>Coding standard</u>  <ul style="list-style-type: none"> <li>00 ITU-T standardized coding</li> </ul> </li> <li>2. <u>Information transfer capability</u>  <ul style="list-style-type: none"> <li>00000 speech</li> <li>01000 unrestricted digital information</li> <li>10000 3.1 kHz audio</li> </ul> </li> <li>3. <u>Transfer mode</u>  <ul style="list-style-type: none"> <li>00 circuit mode</li> </ul> </li> <li>4. <u>Information transfer rate</u>  <ul style="list-style-type: none"> <li>10000 64 kbit/s circuit mode</li> </ul> </li> <li>5. <u>Structure</u>  <ul style="list-style-type: none"> <li>000 default</li> <li>001 8 kHz integrity</li> </ul> </li> <li>6. <u>Configuration</u>  <ul style="list-style-type: none"> <li>00 point-to-point</li> </ul> </li> <li>7. <u>Establishment</u>  <ul style="list-style-type: none"> <li>00 demand</li> </ul> </li> <li>8. <u>Symmetry</u>  <ul style="list-style-type: none"> <li>00 bidirectional symmetric</li> </ul> </li> </ol>

Item No.	Compliance						Descriptions / Notes
	A	B	C	D	E	F	
4.5.6	O						<u>Call identity</u> <u>Call state</u> 1. <u>Coding standard</u> Only ITU-T standardized coding is supported. 2. <u>Call state value</u> All codings except the following are supported : 011001 Overlap Receiving 3. <u>Global interface state value</u> All codings are not supported. <u>Called party number</u> The supported IA5 characters are of '0' to '9' , '#' and '*'. 1. <u>Type of number</u> All digits received will be treated as "unknown" type. 2. <u>Number plan identification</u> The numbering plan "unknown" will be supported. 3. <u>Number digits</u> The maximum number of number digits is 19. <u>Called party subaddress</u> It is not supported. <u>Calling party number</u> The maximum number of number digits is 15. <u>Calling party subaddress</u> It is not supported.
4.5.7			O				
4.5.8			O				
4.5.9				O			
4.5.10		O					
4.5.11				O			

Item No.	Compliance						Descriptions / Notes
	A	B	C	D	E	F	
4.5.12		O					<p><u>Cause</u></p> <p>1. <u>Coding standard</u> Only ITU-T standardized coding is supported.</p> <p>2. <u>Location</u> All codings except the following are supported : 0011 transit network 0111 international network</p> <p>3. <u>Recommendation</u> Only ITU-T Recommendation Q.931 is supported.</p> <p>4. <u>Cause value</u> The cause values 7, 19, 29, 31, 58, 91, 95, 98 are not supported.</p> <p>5. <u>Diagnostics</u> Only the diagnostic field for cause No. 22, 43, 96, 97, 99, 100, 101 and 102 may be generated by the network.</p>
4.5.13			O				<p><u>Channel Identification</u></p> <p>1. <u>The following codings will be supported :</u></p> <p>1.1 <u>Interface identifier present</u> 0 interface implicitly identified</p> <p>1.2 <u>Interface type</u> 0 basic interface</p> <p>1.3 <u>Preferred/Exclusive</u> 0 indicated channel is preferred 1 exclusive; only the indicated channel is acceptable</p> <p>1.4 <u>D-channel indicator</u> 0 the channel identified is not the D-channel</p> <p>1.5 <u>Information channel selection</u> 01 B1 channel 10 B2 channel 11 any channel</p> <p>2. Octets 3.1-3.3 are not supported.</p> <p>3. This information element will not be repeated in a message.</p>

Item No.	Compliance						Descriptions / Notes
	A	B	C	D	E	F	
4.5.14				O			<u>Congestion level</u> It is not supported.
4.5.15		O					<u>Display</u> The maximum length of this information element is 34 octets.
4.5.16	O						<u>High layer compatibility</u>
4.5.17			O				<u>Keypad facility</u> The supported IA5 characters are of '0' to '9', '#', and '*'.
4.5.18	O						<u>Low layer compatibility</u>
4.5.19				O			<u>More data</u> It is not supported.
4.5.20				O			<u>Network specific facilities</u> It is not supported.
4.5.21			O				<u>Notification indicator</u> The codings for Notification description are supported as follows : 0000000 user suspended 0000001 user resumed
4.5.22			O				<u>Progress indicator</u> The following codings are supported : 1. <u>Coding standard</u> 00 ITU-T standardized coding 2. <u>Location</u> 0000 User 0001 Private network serving the local user 0010 Public network serving the local user 0100 Public network serving the remote user 0101 Private network serving the remote user 1010 Network beyond interworking point 3. <u>Progress description</u> 0000001 Call is not end-to-end ISDN 0000010 Destination address is non-ISDN 0000011 Origination address is non-ISDN 0000100 Call has returned to the ISDN

**Compliance With ITU-T Recommendation I.451 (Q.931)**

Basic Rate Access

Item No.	Compliance						Descriptions / Notes
	A	B	C	D	E	F	
4.5.23					O		<u>Repeat indicator</u> It is not supported.
4.5.24				O			<u>Restart indicator</u> It is not supported.
4.5.25				O			<u>Segmented message</u> It is not supported.
4.5.26	O						<u>Sending complete</u>
4.5.27		O					<u>Signal</u> This information element will not be repeated in a message.
4.5.28				O			<u>Transit network selection</u> It is not supported.
4.5.29				O			<u>User-User</u> It is not supported.
4.6							<u>Supplementary Services Information Elements</u>
4.6.1				O			<u>Date/Time</u> It is not supported.
4.6.2				O			<u>Facility</u> It is not supported.
4.6.3		O					<u>Feature Activation</u> The maximum length of this information element is 3 octets.
4.6.4		O					<u>Feature Indication</u> The maximum length of this information element is 4 octets.
4.6.5				O			<u>Switchhook</u> It is not supported.
8.2.5 of Q.932			O				<u>Information Request</u> 1. This information element may be used for service control procedure. 2. The authorization code (000001) and terminal identification (000011) in Type of information (octet 3) are not supported.
4.7				O			<u>Information Elements for Packet Communications</u> It is not supported.

Item No.	Compliance						Descriptions / Notes
	A	B	C	D	E	F	
5.						O	<u>CIRCUIT-SWITCHED CALL CONTROL PROCEDURES</u>
5.1	O						<u>Call establishment at the Originating Interface</u>
5.1.1	O						<u>Call request</u>
5.1.2			O				<u>B-Channel selection - originating</u> No in-band information will be provided.
5.1.3		O					<u>Overlap sending</u> 1. No in-band information will be provided. 2. User should recognize the Setup acknowledge message and reply by one or more Information message. 3. The completion of information sending contain either a 'sending compete' indication (the '#' character or the sending complete information element) or called number information which the network can determine to be complete.
5.1.4	O						<u>Invalid call information</u>
5.1.5							<u>Call Proceeding</u>
5.1.5.1			O				<u>Call proceeding, en-bloc sending</u> 1. The determination of en-bloc sending is by either inclusion of a 'sending complete' indication (the '#' character or the sending complete information element) 2. Cause No. 58 "bearer capability not presently available" is not supported.
5.1.5.2		O					<u>Call proceeding, overlap sending</u> 1. Cause No. 58 "bearer capability not presently available" is not supported. 2. At the expiration of timer T302, the network will: a) initiate call clearing in accordance with 5.3 with cause No. 28 'invalid number format' (incomplete number) sent to the calling user, if the network determines that the call information is definitely incomplete; otherwise; b) send a Call Proceeding message and enter the outgoing call proceeding state.
5.1.6			O				<u>Notification of interworking at the originating interface</u> No in-band information will be provided.
5.1.7	O						<u>Call confirmation indication</u>
5.1.8	O						<u>Call connected</u>
5.1.9	O						<u>Call rejection</u>
5.1.10				O			<u>Transit network selection</u> It is not supported.

**Compliance With ITU-T Recommendation I.451 (Q.931)**

Item No.	Compliance						Descriptions / Notes
	A	B	C	D	E	F	
5.2			O				<u>Call Establishment at the Destination Interface</u> 1. Permanent data link connection is not supported. 2. Setup message offered on point-to-point data link is not supported.
5.2.1			O				<u>Incoming call</u> 1. Only multipoint terminal configuration is supported. 2. Overlap receiving procedure is not supported.
5.2.2		O					<u>Compatibility checking</u> SETUP message delivered via a point-to-point data link is not supported.
5.2.3							<u>B-channel selection - destination</u>
5.2.3.1				O			<u>SETUP message delivered by point-to-point data link</u> It is not supported.
5.2.3.2			O				<u>SETUP message delivered by broadcast data link</u> The indication of "no channel available" is not supported.
5.2.4				O			<u>Overlap receiving</u> It is not supported.
5.2.5							<u>Call confirmation</u>
5.2.5.1			O				<u>Response to en-bloc SETUP or completion of overlap receiving</u> 1. Setup message delivered via a point-to-point data link is not supported. 2. Overlap receiving procedure is not supported.
5.2.5.2			O				<u>Receipt of CALL PROCEEDING and ALERTING</u> 1. Setup message delivered via a point-to-point data link is not supported. 2. Overlap receiving procedure is not supported.
5.2.5.3			O				<u>Called user clearing during incoming call establishment</u> 1. Setup message delivered via a point-to-point data link is not supported. 2. Timer T304 is not supported.
5.2.5.4			O				<u>Call failure</u> 1. Setup message delivered via a point-to-point data link is not supported.
5.2.6			O				<u>Notification of interworking at the terminating interface</u> No in-band information will be provided.
5.2.7	O						<u>Call accept</u>

**Compliance With ITU-T Recommendation I.451 (Q.931)**

Item No.	Compliance						Descriptions / Notes
	A	B	C	D	E	F	
5.2.8			O				<u>Active indication</u> 1. Setup message delivered via a point-to-point data link is not supported. 2. Timer T304 is not supported.
5.2.9	O						<u>Non-selected user clearing</u>
5.3							<u>Call Clearing</u>
5.3.1						O	<u>Terminology</u>
5.3.2			O				<u>Exception conditions</u> Point-to-point data link and temporary signalling connection are not supported.
5.3.3		O					<u>Clearing initiated by the user</u> The restart procedure is not supported.
5.3.4	O						<u>Clearing initiated by the network</u>
5.3.4.1	O						<u>Clearing when tones/announcements provided</u>
5.3.4.2				O			<u>Clearing when tones/announcements not provided</u> It is not supported.
5.3.4.3	O						<u>Completion of clearing</u>
5.3.5			O				<u>Clear collision</u> Timer T306 is not supported.
5.4				O			<u>In-Band Tones and Announcement</u> It is not supported.
5.5				O			<u>Restart Procedure</u> It is not supported.
5.6			O				<u>Call rearrangements</u> After receiving SUSPEND and RESUME messages from user, network does not guarantee NOTIFY message will be sent to the other user.
5.6.1			O				<u>Call suspension</u>
5.6.2			O				<u>Call suspend error</u>
5.6.3			O				<u>Call re-establishment</u>
5.6.4			O				<u>Call resume errors</u>
5.6.5			O				<u>Double suspension</u>
5.6.6			O				<u>Call re-arrangement notification controlled by an NT2</u>
5.6.7			O				

Item No.	Compliance						Descriptions / Notes
	A	B	C	D	E	F	
5.7	O						<u>Call Collisions</u> The requirement of the interface at reference point R is not within the scope of this specification.
5.8	O						<u>Handling of Error Conditions</u>
5.8.1	O						<u>Protocol discrimination error</u>
5.8.2	O						<u>Message too short</u>
5.8.3							<u>Call reference error</u>
5.8.3.1	O						<u>Invalid call reference format</u>
5.8.3.2		O					<u>Call reference procedural errors</u> Messages using global call reference are not expected to be received.
5.8.4		O					<u>Message type or message sequence errors</u> 1. Cause No. 97 and cause No. 101 will be generated by the network but not cause No. 98. 2. Cause No. 111 or No. 31 may be sent to remote user if unexpected RELEASE COMPLETE message is received.
5.8.5			O				<u>General information element errors</u> 1. Codesets other than codeset 0 are not supported. 2. The diagnostic field in Cause information element will be supported for causes No. 43, No. 96, No. 97, No. 99, No. 100, No. 101 and No. 102. 3. The diagnostic field in Cause information element with No. 22 may be provided by network.
5.8.5.1		O					<u>Information element out of sequence</u> 1. The network will transmit the information elements in sequence. 2. All out of sequence information elements will be ignored.
5.8.5.2	O						<u>Duplicated information elements</u>
5.8.6							<u>Mandatory information element errors</u>
5.8.6.1	O						<u>Mandatory information element missing</u>
5.8.6.2	O						<u>Mandatory information element content error</u>
5.8.7					O		<u>Non-mandatory information element errors</u>
5.8.7.1	O						<u>Unrecognized information element</u>
5.8.7.2		O					<u>Non-mandatory information element content error</u> Access information element with a length exceeding the maximum length shall be discarded and relevant cause values shall be sent to user.

Item No.	Compliance						Descriptions / Notes
	A	B	C	D	E	F	
5.8.8			O				<u>Data link reset</u> Overlap receiving procedure is not supported.
5.8.9			O				<u>Data link failure</u> 1. When informed of Layer 2 reestablishment by means of the DL-ESTABLISH-CONFIRM primitive, the network will stop timer T309 and may periodically send the STATUS ENQUIRY message for calls in Active state. 2. Packet mode access connection is not supported.
5.8.10		O					<u>Status enquiry procedure</u> The network may periodically send STATUS ENQUIRY message in Active state.
5.8.11			O				<u>Receiving a STATUS message</u> 1. On receipt of a Status message reporting an incompatible state, the receiving entity shall clear the call by sending the appropriate clearing message with cause No. 101 "message not compatible with call state". However, user side entity may take other actions which attempt to recover from a mismatch and which are an implementation option. 2. If a STATUS message indicating any call state except the Active state is received in the Active state, the network may send a DISCONNECT message with cause No. 101 "message not compatible with call state", and enter Disconnect indication state. 3. A Status message may be received indicating a compatible call state, in this case the network will clear the call with appropriate procedure defined in 5.3, using the cause specified in the received Status message. In case of user, the actions to be taken are an implementation option. 4. A STATUS message specifying the global call reference is not expected to be received.
5.9			O				<u>User Notification Procedure</u> The network will relay the NOTIFY message for call suspension and resumption.
6.				O			<u>PACKET COMMUNICATIONS PROCEDURES</u> It is not supported.
7.				O			<u>USER-TO-USER SIGNALLING PROCEDURES</u> It is not supported.
8.		O					<u>APPLICATION OF CIRCUIT SWITCHED SUPPLEMENTARY SERVICES TO TERMINALS USING STIMULUS PROCEDURES</u> Stimulus procedures for supplementary services will be described separately.

Item No.	Compliance						Descriptions / Notes
	A	B	C	D	E	F	
9.							<u>LIST OF SYSTEM PARAMETERS</u>
9.1			O				<u>Timers in the Network Side</u> 1. Timers T304, T314, T316, T317, T320, and T321 are not supported. 2. Timer T301 minimum value is 2 minutes. 3. Timer T302 is 10 seconds.
9.2		O					<u>Timers in the User Side</u> 1. The timers under this section are subject to user implementation. 2. Timers T302, T314, T316, T317, T321 are not recommended.

SECTION II  
APPENDIX A

USAGE OF CAUSE VALUES

Table A-1 defines the key for the location of generation in Table A-2. For more precise usage of the location codes in the cause information element, see Annex G/Q.931.

TABLE A-1

Key for the location of the generation in Table A-2

LU : Local user  
LN : Local network  
RU : Remote user

Table A-2 indicates the usage of cause values within the Specification Section II Part D (Q.930) and Part E (Q.931). Other usage may be provided within other ITU-T Recommendations, e.g. Q.700-Series and Q.699. Other causes may also be used by Q.931 entities where this is not precluded by the procedures defined elsewhere in this Specification.

The following abbreviations to message types are used in Table A-2

DISC	DISCONNECT
REL	RELEASE
REL COM	RELEASE COMPLETE
RES REJ	RESUME REJECT
STAT	STATUS
SUSP REJ	SUSPEND REJECT

When the Cause information element with or without diagnostic(s) field is specified by the user, this information element will be carried transparently by the network.

TABLE A-2 (1 of 8)  
Usage of Cause Values

Cause No.	Class	Value	Cause Name	Diagnostics	Section cross-reference	Typical location of generation	Typical carrying message as identified by receiving side	
							At remote interface	At local interface
1	000	0001	Unassigned (Unallocated) number	-	5.1.4	LN		REL COM DISC
					5.2.4	RU	REL COM DISC	
3	000	0011	No route to destination	-	5.1.4	LN		DISC REL COM
					5.2.4	RU	REL COM DISC	DISC
6	000	0110	Channel unacceptable	-	5.2.3.1c 5.3.2d	LN		REL
16	001	0000	Normal call clearing	Condition		RU	DISC	DISC
17	001	0001	User busy	-	5.2.5.1 5.2.5.4b	RU	REL COM	DISC
					No procedure	LN		DISC
18	001	0010	No user responding	-	5.2.5.3	LN		DISC
19	001	0011	User alerting, no answer	-	5.2.5.3	LN		DISC

TABLE A-2 (2 of 8)  
Usage of Cause Values

Cause No.	Class	Value	Cause Name	Diagnostics	Section cross-reference	Typical location of generation	Typical carrying message as identified by receiving side	
							At remote interface	At local interface
21	001	0101	Call rejected	Condition: user supplied diagnostic	5.2.5.1 5.2.5.4b	RU	REL COM	DISC
22	001	0110	Number changed	New destination number (The diagnostic field may be provided by network.)	5.1.4	LN		DISC REL COM
					5.2.4	RU	REL COM DISC	DISC
26	001	1010	Non-selected user clearing	-	5.3.2 b)	LN		REL
27	001	1011	Destination out of order	-	5.8.9	LN		DISC
28	001	1100	Invalid number format (incomplete number)	-	5.2.4	RU	DISC REL COM	DISC
					5.1.5.2	LN		DISC
					5.2.4	LN		DISC
					5.1.4	LN		DISC REL COM

TABLE A-2 (3 of 8)  
Usage of Cause Values

Cause No.	Class	Value	Cause Name	Diagnostics	Section cross-reference	Typical location of generation	Typical carrying message as identified by receiving side	
							At remote interface	At local interface
29	001	1101	Facility rejected	-	No procedure	LN		REL COM DISC
						LN		DISC
						RU	REL COM DISC	
30	001	1110	Response to STATUS ENQUIRY	-	5.8.10	LU, LN		STAT
31	001	1111	Normal, unspecified	-	5.8.4	LN		REL COM DISC
34	010	0010	No circuit/channel available	-	5.1.1 5.1.2	LN		REL COM
					5.2.3.1b 5.2.3.1e 5.2.3.2	RU	REL COM	DISC
38	010	0110	Network out of order	-	No procedure			
41	010	1001	Temporary failure	-	5.8.8	LU, LN		DISC
					5.8.10	LN, RU	DISC	DISC

TABLE A-2 (4 of 8)  
Usage of Cause Values

Cause No.	Class	Value	Cause Name	Diagnostics	Section cross-reference	Typical location of generation	Typical carrying message as identified by receiving side	
							At remote interface	At local interface
42	010	1010	Switching equipment congestion	-	No procedure			REL REL COM
43	010	1001	Access information discarded	Discarded info element identifier (s)	5.8.7.2	LN, LU		STAT
44	010	1100	Requested circuit/channel not available	-	5.1.2	LN		REL COM
					5.2.3.1e 5.2.3.2	RU	REL COM	DISC
47	010	1111	Resource unavailable, unspecified	-	No procedure			
50	011	0010	Requested facility not subscribed	-	8	LN		DISC REL COM PROG
57	011	1001	Bearer capability not authorized	-	5.1.5.2	LN		DISC REL COM
63	011	1111	Service or option not available, unspecified	-	5.1.5.2	LN		DISC REL COM

TABLE A-2 (5 of 8)  
Usage of Cause Values

Cause No.	Class	Value	Cause Name	Diagnostics	Section cross-reference	Typical location of generation	Typical carrying message as identified by receiving side	
							At remote interface	At local interface
65	100	0001	Bearer capability not implemented	-	5.1.5.2	LN		DISC REL COM
					6	LN		REL COM
66	100	0010	Channel type not implemented	-	No procedure			
69	100	0101	Requested facility not implemented	-	8	LN		DISC REL COM PROG
70	100	0110	only restricted digital information bearer capability is available	-	No procedure			
79	100	1111	Service or option not implemented, unspecified	-	7.1	LN		STAT

TABLE A-2 (6 of 8)  
Usage of Cause Values

Cause No.	Class	Value	Cause Name	Diagnostics	Section cross-reference	Typical location of generation	Typical carrying message as identified by receiving side	
							At remote interface	At local interface
81	101	0001	Invalid call reference value	-	5.8.3.2a	LU, LN		REL REL COM
					5.8.3.2b	LU, LN		REL COM
					5.8.3.2f	LU, LN		STAT
82	101	0010	Identified channel does not exist	-	No procedure			REL COM
83	101	0011	A suspended call exists, but this call identity does not	-	5.6.5	LN		RES REJ
84	101	0100	Call identity in use	-	5.6.3	LN		SUSP REJ
85	101	0101	No call suspended	-	5.6.5	LN		RES REJ
86	101	0110	Call having the requested call identity has been cleared	-	5.6.5	LN		RES REJ
88	101	1000	Incompatible destination	Incompatible parameter	5.2.2 5.2.5.1 5.2.5.3a B.3.2, B3.3	RU	REL COM	DISC

TABLE A-2 (7 of 8)  
Usage of Cause Values

Cause No.	Class	Value	Cause Name	Diagnostics	Section cross-reference	Typical location of generation	Typical carrying message as identified by receiving side	
							At remote interface	At local interface
96	110	0000	Mandatory information element is missing	Information element identifier (s)	5.8.6.1	LN, LU		REL REL COM STAT
					5.8.11	LN, LU		STAT
97	110	0001	Message type non-existent or not implemented	Message type	5.8.4 5.8.10 5.8.11	LU, LN		STAT
99	110	0011	Information element non-existent or not implemented	Information element identifier (s)	5.8.7.1 5.8.11	LU, LN		STAT
					5.8.7.1	LN		REL REL COM
100	110	0100	Invalid information element contents	Information element identifier (s)	5.8.6.2	LU, LN		STAT REL REL COM
					5.8.7.2 5.8.11	LU, LN		STAT
101	110	0101	Message not compatible with call state	Message type	5.8.4	LN, LU		STAT
					5.8.11	LN, LU		DISC REL REL COM

TABLE A-2 (8 of 8)  
Usage of Cause Values

Cause No.	Class	Value	Cause Name	Diagnostics	Section cross-reference	Typical location of generation	Typical carrying message as identified by receiving side	
							At remote interface	At local interface
102	110	0110	Recovery on timer expiry	Timer number	5.2.4 5.2.5.3 5.4.1 5.6.5	LN		DISC
					5.3.3 5.3.4	LN		REL
					5.3.2f 5.3.3 5.6.5	LU		REL
111	110	1111	Protocol error, unspecified	-	5.8.4	LN		DISC
127	111	1111	Interworking unspecified	-	No explicit procedure			