



Perspective and Issues of Convergence – Hong Kong, China

Mr. Lawrence SM Kwan
Chief Telecommunications Engineer
OFTA, Hong Kong, China

25 March 2008

Regulatory Roundtable on “Convergence :
What Does this Mean Now ?”, APEC TEL37, Tokyo, Japan



What Leads to Convergence

- **Evolution in core and access networks**
 - ▶ IP-based core network of NGN can be connected to different types of access networks
 - ▶ Access networks can connect fixed and moving customers (e.g. WiMax)
- **Capability of service platforms**
 - ▶ Single platform with multiple services
 - ▶ Increasingly services can be provided on a single IP-based network
- **Integration of functions**
 - ▶ Single equipment with multiple functions (e.g. 3G phone with voice, Internet access and TV receiver functions)
 - ▶ Result in blurring of boundary between fixed/ mobile services and telecommunications / broadcasting services
- **Market change**
 - ▶ Merge of separate market segments

Service Provider Convergence

- Service provider has capability to offer services that could be provided only by one type of service provider previously

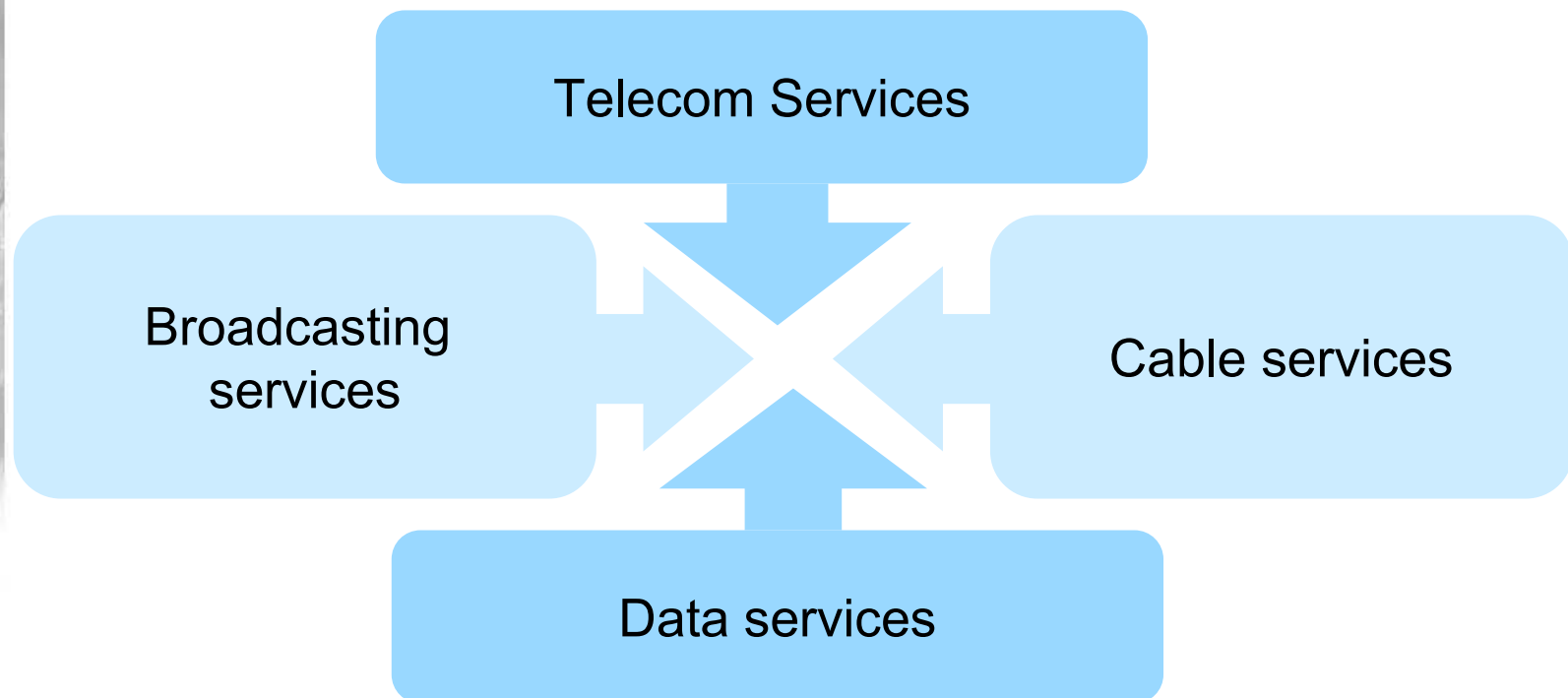

Convergence of Service Platforms

- **Broadband wireless technologies delivering both fixed and mobile services**
- **IP Multimedia Sub-system (IMS), an enabling service platform which offers to support fixed and mobile services**

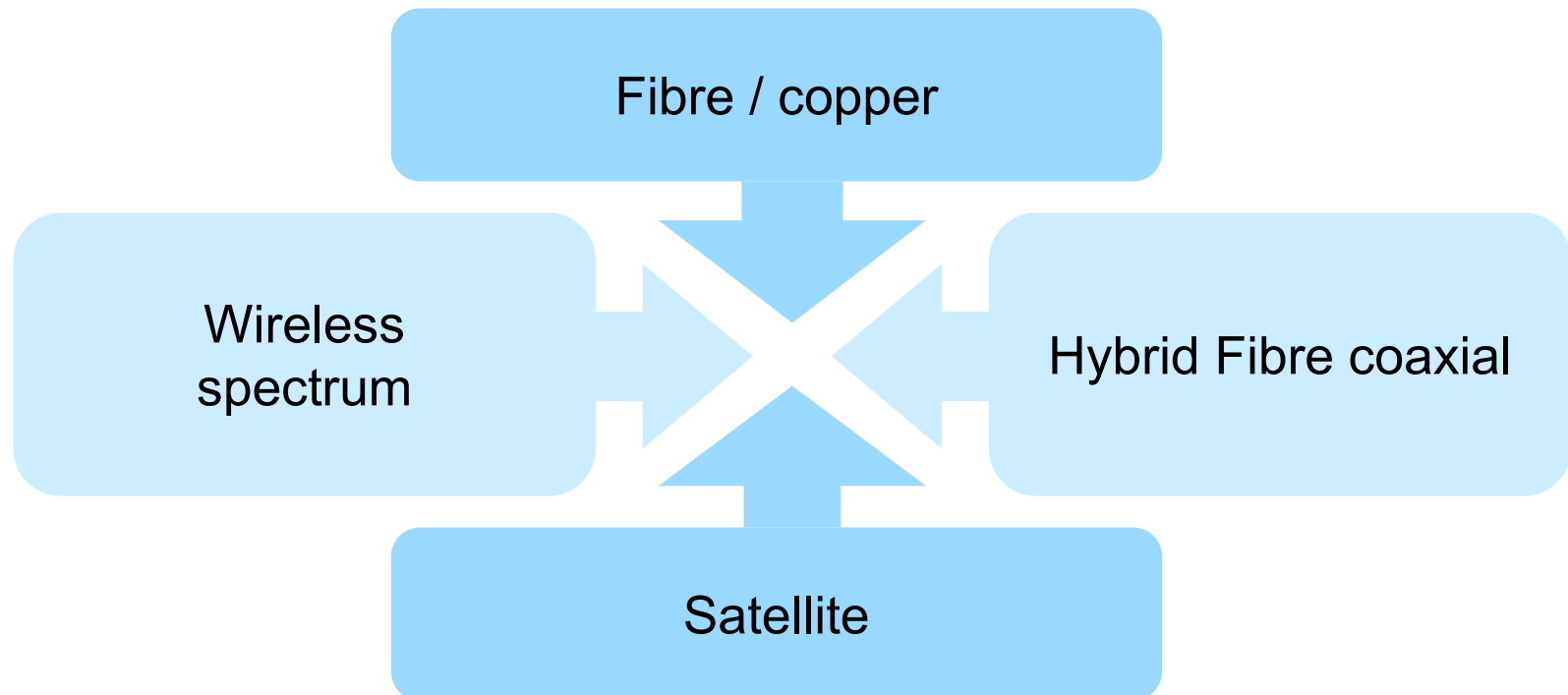

Convergence of Markets

- **Previously separate market segments merged**
 - ▶ Mobile fixed substitution
 - ▶ Triple play packages offered by cable TV operator and telecom operator

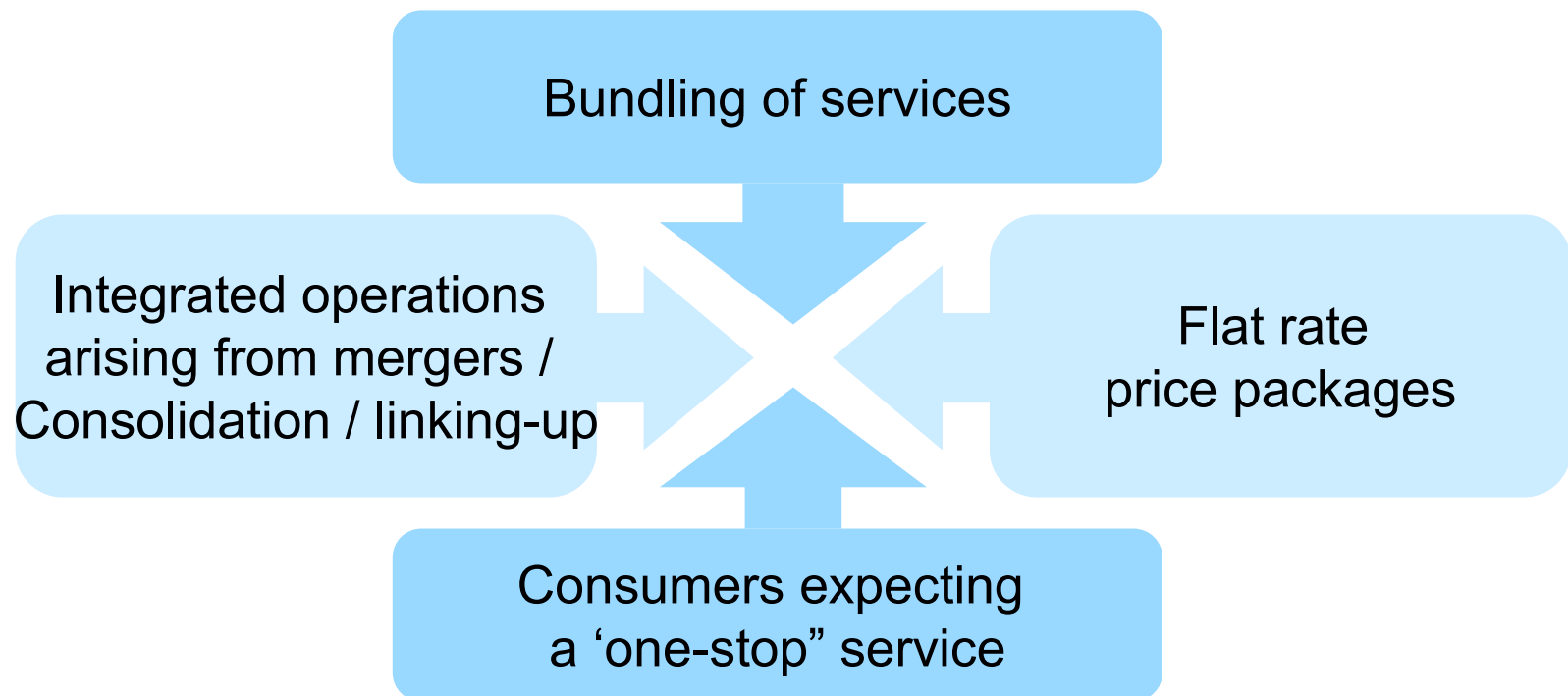

Terminal Equipment Convergence

- Integrated customer terminal equipment allows end users to access a variety of services that would require multiple terminals previously

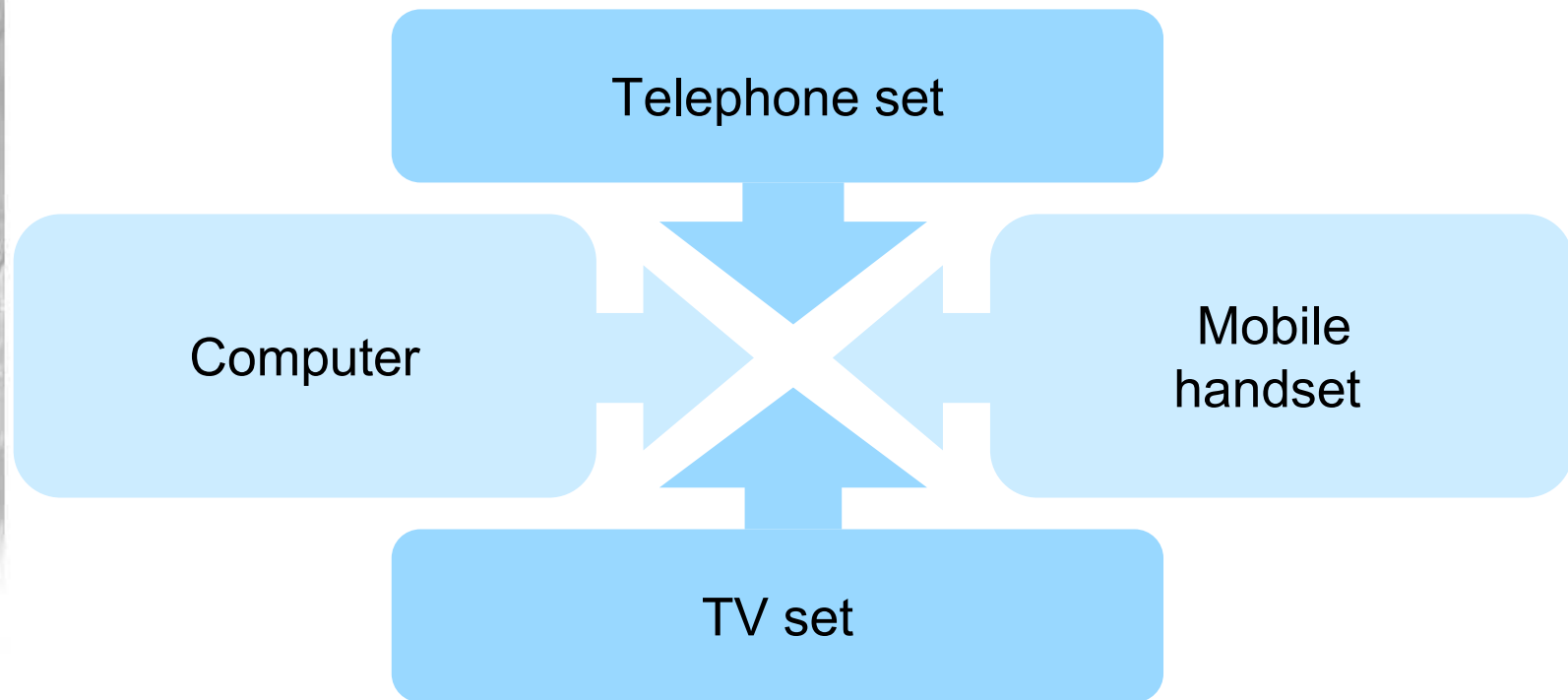



Enabling Technologies

- **Access network**
 - ▶ Cellular (e.g. 2G, 3G)
 - ▶ Fixed wireless (e.g. WiMax)
 - ▶ Fixed (e.g. xDSLs, FTTx, HFC)
 - ▶ WiFi
 - ▶ Power line
- **Services**
 - ▶ VoIP
 - ▶ Broadband Internet Access
 - ▶ IPTV



Opportunities

- 
- Promote competition – stakeholders to derive full benefits from convergence
 - Lower costs in long run
 - Encourage development of innovative services and enabling technologies
 - Service packages tailored made to customers to suit communications needs



Challenges (1)

- **Policy and regulatory framework**
 - ▶ Needs to be revised to cater for the new converged environment
 - ▶ Protect consumer interests and facilitate environment conducive to investment
 - ▶ Forward-looking and adaptable regulatory framework is necessary
- **Licensing regime**
 - ▶ More efficient, non service-specific licensing regime
 - ▶ Some service specific licences are likely to be replaced by unified licences / class licences



Challenges (2)

- **Role of Regulator**

- ▶ Set up environment to facilitate convergence
- ▶ Allow market forces to decide the direction, extent and pace of convergence
- ▶ Adopt *ex ante* or *ex post* regulation ?

- **Legacy networks**

- ▶ Migration of conventional telephone networks to IP-based NGN



Vision of a Converged World

- Consumers use a single terminal to access any desired information available in any network without limitation
- With the advent of IP, competition in telecom services becomes a global phenomenon and is no longer confined to within the national or regional boundary
- Policy-makers and regulators will need to put in place a forward-looking and adaptable regulatory framework



Existing Situation

- Separate regulatory authorities for telecom and broadcasting services
- Both telecom and broadcasting markets are fully liberalized
- Distinct regulatory frameworks for the mobile carriers and fixed carriers
- Open licensing regime for both fixed and mobile market, except that entry to the mobile market is constrained by the availability of spectrum



Existing Situation

- **Conclusion of fixed mobile convergence:**
 - ▶ **the introduction of an unified carrier licence**
 - ▶ **deregulation of existing asymmetry regulations and regime for fixed and mobile service**
 - ▶ **study the need of fixed-mobile number portability**
- **Spectrum Policy Review**
 - ▶ **Including adoption of market-based approach for spectrum management, spectrum rights, spectrum trading and liberalization**



Works Ahead

- Reform of licensing regime
 - ▶ Unified Carrier Licence (UCL)
 - ▶ Streamlining of licensing framework
- Set up of converged regulator
- Development of regulatory framework for NGN



Unified Carrier Licence

- Unified Carrier Licence (UCL) is a feasible approach to address the licensing issues due to convergence
 - ▶ To remove obstacle to fixed-mobile convergence
 - ▶ No immediate impact on market structure
 - ▶ Offers the flexibility of licensing both fixed and mobile services under one licence
- Creation of unified Carrier Licence
 - ▶ OFTA has completed a public consultation on the creation of a UCL by 4 March 2008
 - ▶ Submissions of comments / views are being studied
 - ▶ Conclusion may be available in a few months



Unified Carrier Licence

- Issues addressed in the Consultation Exercise (1) :
 - ▶ Rights and Obligations under UCL
 - Rights commensurate with scope of service
 - Obligations are basically modelled on that specified in existing fixed / mobile carrier licences
 - ▶ Interconnection regime
 - Follow prevailing interconnection arrangements for carrier-to-carrier interconnection
 - Regulatory guidance for fixed mobile interconnection charge (“FMIC”) and interconnection links will be withdrawn in April 2009



Unified Carrier Licence

- Issues addressed in the Consultation Exercise (2) :
 - ▶ Migration to UCL regime
 - Replacement of FTNS / Fixed Carrier Licences upon expiry in 2010
 - Conversion of Mobile Carrier Licences



Converged Regulator

- 
- Converged regulator of telecoms and broadcasting to be formed to oversee telecoms and broadcasting matters, as boundaries are blurred
 - Relevant laws / ordinances / regulations need to be harmonised or enacted



Regulatory Framework for NGN

- 
- Some operators formulated roadmaps for migration from their legacy networks to NGNs
 - Some are already in NGN form
 - Migration is progressive to meet the business models of operators
 - Regulate or not? A new regulatory framework for NGN era to be developed?



Possible Issues of NGN

- 
- Interconnection Regime
 - Numbering and Addressing
 - Universal Service Obligation
 - Lawful Interception
 - Network Security
 - Access to Emergency Services
 - Standardization and Interoperability



Interconnection Regime

- 
- Existing interconnection regime based on circuit-switched networks may have to be reviewed to cater for IP-based networks
 - Any new interconnection regime and charging model to be developed should be technology / service neutral to cater for further evolution
 - Issues such as open / equal access, A2A, regulations on interconnection and QoS need to be properly addressed to facilitate effective competition while fostering the incentives for further investment



Numbering and Addressing

- Existing E.164 numbering scheme is widely deployed in the existing PSTN, VoIP, and future migration to all IP-based NGN services
- Extension of E.164 numbering resources from the current 8 digits to longer digits in case of strong demand of numbers for convergence and NGN services
- Keep track of ENUM development to consider future implementation



Universal Service Obligation

- Diminishing scale and scope of USO in HK
- Some economies may have included broadband services in USO
- Whether other services are to be included in USO in light of NGN is subject to study and consultation
- To keep track of the international development of USO in NGN perspective



Lawful Interception

- 
- Lawful interception solution to intercept IP packets transmitted over the NGN required
 - Cost is a major consideration in the implementation of lawful interception
 - Study of operators' ability and minimum requirements in the support of lawful interception in NGN



Network Security

- Security threats in the Internet world extended to IP-based networks
- NGN operators to adopt appropriate security measures and protection of their facilities/operation
- Coordination/cooperation among government, industry and users to combat the risks imposed



Access to Emergency Services

- 
- Access to emergency services should remain an essential provision or obligation in convergence and IP-based environment
 - Recommendations from ITU and ETSI support all PSTN-interconnected IP telephony service to provide access to emergency services in NGN domain



Standardization and Interoperability

- 
- International standardization bodies like ITU, ETSI, 3GPP, IETF and etc. are now developing standards for NGN
 - Examples: Network-Network Interface (NNI), User-Network Interface (UNI), User-Application Interface (UAI), etc.
 - May need requirements on codec, QoS and security to ensure service interoperability



Way Forward

- Implement recommendations and decisions of fixed mobile convergence
- Consolidate the consultation of Unified Carrier Licence regime
- Study the issues of NGN and make consultations
- Keep track of international developments



Thank You