

# **Requirements for Mobile Number Portability by Database Solution**



**Telecommunications Authority  
Hong Kong**

**Revision History**

Issue No.	Date Issued	Note
1	August 1998	Issued by the Telecommunications Authority (TA) for the initial launch of Mobile Number Portability (MNP).
2	August 2000	Issued by the TA after refinements.
3	February 2001	Issued by the TA after the use of electronic documents to replace fax transaction.

**Contents**

**Section 1 General**

**Section 2 Definition of Terms**

**Section 3 Operators' Responsibilities**

**Section 4 Number Porting Activation and Termination**

**Section 5 Fault Handling Procedures**

**Section 6 Numbering Allocations**

**Section 7 Performance Requirements**

**Annex A Information Exchange**

**Annex B Gateway Number Allocation**

**Annex C Functional Requirements of Administration Database**

## Requirements for Mobile Number Portability by Database Solution

### 1. General

- 1.1 Mobile number portability (MNP) is the ability for a customer to retain his/her assigned mobile telephone number when changing the subscriptions from one mobile network operator to another mobile network operator.
- 1.2 The Mobile (Public Mobile Radiotelephone Services and Personal Communications Services) and Fixed Telecommunication Network Services licensees (hereafter referred to as the **Network Operators**) are required to provide the function of mobile number portability among their networks.
- 1.3 This document sets out the interface requirements allowing mobile number portability whereby the routing information is obtained by making reference to a database, such as the one established in an **intelligent network (IN)**. In this connection, unless otherwise stated to the contrary, the telephone calls considered in this document will be restricted to calls involving ported mobile numbers only. The functional specifications for non-porting mobile numbers are included in this document for reference.
- 1.4 This document should not cause conflicts with calls not involving ported numbers.

### 2. Definition of Terms

<b>Administration (AD):</b>	<b>Database</b>	The off-line database that mainly performs the backup and auditing role for all ported-out and ported-in numbers, and is required to store all mobile network operators' working and history records of ported-out and ported-in numbers and their corresponding information.
<b>AD Maintenance (MA):</b>	<b>Agent</b>	The AD Maintenance Agent is the Network Operator designated to be responsible for the agreed operation, administration and maintenance work of the physical AD server.
<b>Directory Number (DN):</b>		The telephone number that is dialled by a calling party to reach the called party. If the called party is a mobile customer which has been ported from the Donor Network to the

	Recipient Network, this is the same as the Ported Number.
<b>Donor Network Operator (DNO):</b>	Operator of the Mobile Network from which the number is being or has been ported.
<b>Donor Network:</b>	The Network of the DNO.
<b>DNO MA:</b>	The MA of the DNO.
<b>GN Database:</b>	The database that provides translation of the ported number into the gateway number (GN).
<b>MNP Provider:</b>	The Network Operator which provides number portability translation service to the Originating Network for the purpose of routing of calls to the Recipient Network. A MNP Provider may also play the role of a transit network if requested by the originating network.
<b>Network Operator:</b>	A Mobile Licensee (providing Public Mobile Radiotelephone Services and/or Personal Communications Services) or a Fixed Telecommunication Network Services (FTNS) Licensee.
<b>Original DNO:</b>	Operator of the Mobile Network from which the number was first ported.
<b>Originating Network:</b>	The Mobile or Fixed Network from which a call is originated.
<b>Other MA:</b>	The MA who is neither representing RNO nor DNO for the porting request.
<b>Ported Number:</b>	Mobile number of a customer which has been ported from the Donor Network to the Recipient Network.
<b>Receiving Network Operator:</b>	The network operator that retrieves information exchange files from the sending network operators.
<b>Recipient Network Operator (RNO):</b>	Operator of the Mobile Network which has gained the ported number.
<b>Recipient Network:</b>	Network of the RNO.

<b>RNO MA:</b>	The MA of the RNO.
<b>Sending Network Operator:</b>	The network operator that sends information exchange files to other network operators.
<b>Terminating Network:</b>	The mobile network to which the called number is connected. By inference, this is the same as the Recipient Network.
<b>Transit Network:</b>	The network which is involved in carrying a call between the Originating Network and the Terminating Network but which is neither the Originating nor the Terminating Network.

### 3. Operators' Responsibilities

#### 3.1 Requirements on Originating Network

- 3.1.1 Calls originating in the Originating Network shall be passed to the Recipient Network over one or more pre-determined **Points of Interconnection(s) (POI)**.
- 3.1.2 The Originating Network has to recognize a call to a ported number and translate it into a **Gateway Number (GN)** pre-determined by the Recipient Network before it delivers the call to Recipient Network. The call is then routed to the Recipient Network using the Gateway Number. Unique blocks of GN will be centrally allocated by the TA to each Network Operator. The Originating Network can, with mutual agreement, rely on a MNP Provider to provide number translation and/or routing services for ported number recognition, GN translation and/or routing of the call to the Recipient Network.
- 3.1.3 The Originating Network shall ensure that calls destined for numbers residing on its own network shall not be passed to another network except its own MNP provider(s).
- 3.1.4 Calls delivered from the Originating Network to the Recipient Network should use a routing which is technically and operationally most efficient.

#### 3.2 Requirements on Transit Network

- 3.2.1 Calls passing through the Transit Network shall be routed to the Recipient Network over one or more pre-determined Points of Interconnection(s) (POI).
- 3.2.2 The Transit Network has to route the call to the Recipient Network in a way which is technically and operationally most efficient.

### **3.3 Requirements on MNP Provider and MA**

#### **General**

- 3.3.1 In this document, all the defined responsibilities would refer to the Network Operators only, although the Network Operators could delegate the concerned responsibilities to its MNP Provider(s) and/or its MA(s). Every Network Operator should nominate one or more MNP Provider and MA, which may be the Network Operator itself. The Network Operator should ensure proper coordination between its MNP Provider(s) and its MA(s).

#### **MNP Provider**

- 3.3.2 A MNP provider has to provide database look-up and number portability translation service to its associated Originating Network for the purpose of routing of calls to the Recipient Network. The MNP Provider has the responsibility to update its GN Database on behalf of its associated Network Operator.

#### **MA**

- 3.3.3 A MA is responsible for the agreed operation, administration and maintenance work of the physical AD server as designated by a Network Operator. The MA has the responsibility to update its AD on behalf of its associated Network Operator.

### **3.4 Requirements on Donor Network**

- 3.4.1 The Donor Network Operator (DNO) shall ensure that any ported number is not reassigned to another customer of the DNO unless and until the number is relinquished by the Recipient Network Operator (RNO).
- 3.4.2 The DNOs will, at such intervals as may be directed by the TA, file reports to the TA on details of numbers ported from their networks.

### **3.5 Requirements on Recipient Network**

- 3.5.1 After having received a call over the POI from the Originating Network (or Transit Network), the Recipient Network will connect the call to the destined ported number in a manner that is technically and operationally most efficient.
- 3.5.2 Under the conditions where Calling Line Identity (CLI) is transferred, calls originated by the ported number shall have the CLI set to the Directory Number and not to any other number that may be used by the Recipient Network for completing incoming calls.

- 3.5.3 When a ported number ceases to be used in the Recipient Network, the ported number shall be relinquished by the RNO and returned to the Original DNO (see also Section 4.3).
- 3.5.4 RNOs will, at such intervals as may be directed by the TA, file reports to the TA on details of numbers ported to their networks.

### **3.6 Requirements on GN Database**

- 3.6.1 The RNO needs to send the necessary ported number information, as defined in Annex A, to the DNO and all other concerned Network Operators. Such information may then be kept in the GN databases of all MNP Providers which store the necessary routing information for implementing MNP.
- 3.6.2 Network Operators are encouraged to deploy a common interface standard for their database. However, in order that Network Operators may retain sufficient control and flexibility over the implementation of their own networks, the common interface standard may incorporate a number of variants, as may be determined jointly by the Network Operators and the TA.
- 3.6.3 Means should be provided to ensure that for the purpose of MNP, the minimum number of interrogations to the database would be required. Nevertheless, the actual number of interrogations to the database could be more than the minimum due to considerations other than the number portability requirements, and will be determined by the respective Network Operators.
- 3.6.4 Means should be provided to ensure that the data for each newly ported number or newly relinquished number is effected in a concurrent manner on all databases and that an audit trail should be available to ensure that data integrity is maintained.
- 3.6.5 Applications of the information on the databases shall be restricted to those for operational purposes, such as for routing of calls and fault handling. Without bilateral agreement, Network Operators shall not make use of the information obtained from the databases for any other purposes.

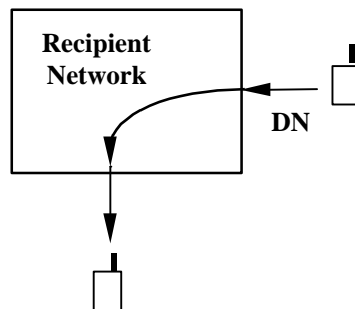
### **3.7 Requirements on Administration Database (AD)**

The functional requirements for the AD should be referred to Annex C and the HKTA 2104 - Functional Specification of Administration Database for Mobile Number Portability.

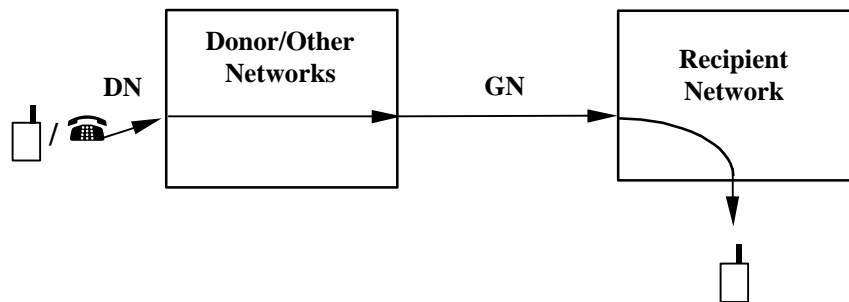
### **3.8 Implementation Options of MNP**

- 3.8.1 *Option 1 - Self-Built MNP Function*** : Under the basic requirement, the Originating Network has to recognize a call to a ported number and translate it to a Gateway Number (GN) pre-determined by the Recipient Network. The Originating Network may meet this requirement by building its own MNP function. This is illustrated in the following Figure 3-1 and 3-2.

**Figure 3-1 Calls to Ported Number Originated by Recipient Network with self-built MNP function**

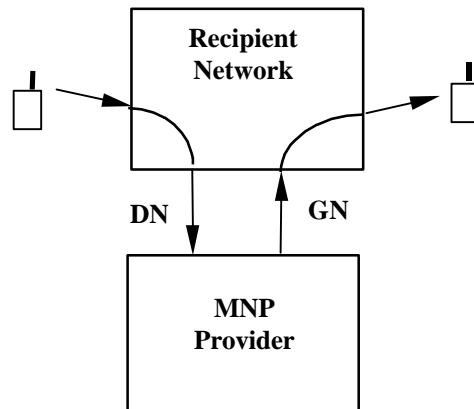


**Figure 3-2 Calls to Ported Number originated by Donor Network or Other Network (Network other than Donor and Recipient Network) with self-built MNP function**

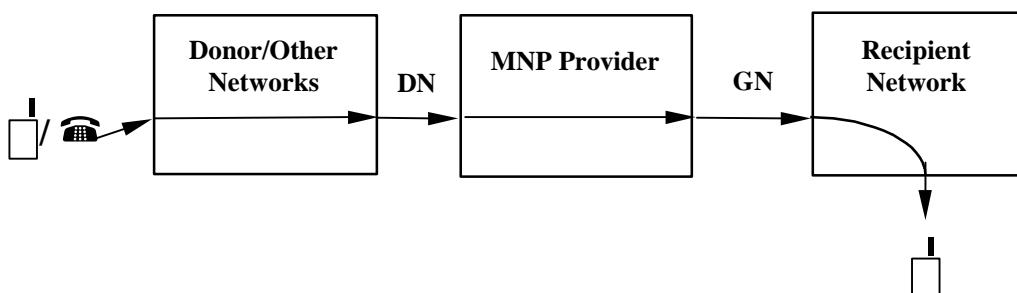


**3.8.2 Option 2 - Call Routing to External MNP Provider :** The Originating Network can, on mutual agreement, pass its originating calls to a MNP Provider for GN translation and transiting of calls to the Recipient Network. This is illustrated in the Figures 3-3 and 3-4.

**Figure 3-3 Calls to Ported Number Originated by Recipient Network which are passed to a MNP Provider for Number Portability Database Look-up and Routing**

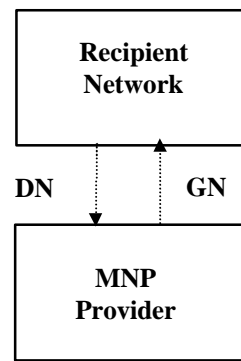


**Figure 3-4 Calls to Ported Number Originated by Donor Network or Other Network (Network other than Donor and Recipient Network) which are passed to a MNP Provider for Number Portability Database Look-up and Routing**

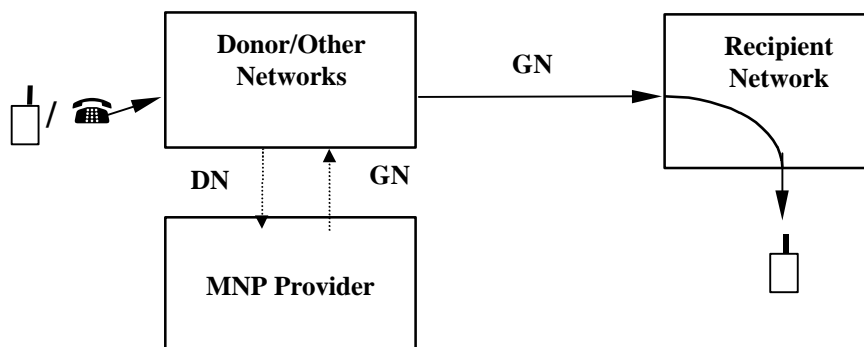


**3.8.3 Option 3 - Access to External GN Database:** The Originating Network can, on mutual agreement, establish a signalling link to the GN database of a MNP Provider in order to recognize a call to a ported number and perform GN translation. The call is then routed from the Originating Network to the Recipient Network using the GN over one or more pre-determined POIs. This is illustrated in the following Figures 3-5 and 3-6. The requirements for the signalling data link interface should be referred to paragraph 3.6.2.

**Figure 3-5 Calls to Ported Number Originated by Recipient Network which are passed to a MNP Provider for Number Portability Database Look-up only**



**Figure 3-6 Calls to Ported Number Originated by Donor Network or Other Network (Network other than Donor and Recipient Network) relying on a MNP Provider for Number Portability Database Look-up only**



- 3.8.4 An individual Network Operator may choose any combination of the above for actual implementation of MNP.

## 4. Number Porting Activation and Termination

### 4.1 Number Porting Service Request and Activation Process

#### General

- 4.1.1 Each Network Operator will be responsible for number portability internal to its own network and which does not affect other Network Operators. This document describes the inter-operator MNP procedures that require joint or coordinated activities. To achieve MNP, each Network Operator should nominate one or more MNP Provider and MA, which could be the Network Operator itself, to provide GN database look-up and other logistic services. The internal procedures and agreement between a Network Operator and its MNP Provider(s) and MA(s) are outside the scope of this document.

## Negotiation Phase

- 4.1.2 The RNO will send a Number Portability Request (NPR) with proposed cutover date/time to the DNO at least 24 working hours in advance of the proposed cutover date and time (see paragraph 4.1.7). On receipt of the NPR from the RNO, the DNO performs initial checks and carries out necessary steps to facilitate the porting of the number concerned

If initial checks are passed, the DNO will reply the RNO by sending an Acknowledgment to NPR (AKNPR) to the RNO. For NPRs received by the DNO from the RNO in the morning session (09:00-12:00), the DNO should reply before 16:00 in the same day. For NPRs received by the DNO from the RNO in the afternoon session (12:00-18:00), the DNO should reply before 16:00 in the next day.

If problems are found in the initial checks, the DNO will send a Negotiation of NPR (NTNPR) to the RNO to advise of the problem(s) and, if appropriate, any suggestion(s) to resolve the problem(s). On receipt of the NTNPR, depending on the nature of the problem(s), the RNO will either further negotiate and issue revised NPR(s) to DNO or issue Cancellation of NPR (CLNPR) to DNO.

## Provisioning Phase

- 4.1.3 On receipt of AKNPR from the DNO, the RNO will then send an Advice of Portable Number (APN) with the cutover details (described in Annex A) to all the Network Operators in advance of the agreed cutover date and time. The APN should be sent by the RNO before 17:30 of the same day for NPRs in the morning session and before 17:30 of the next day for NPRs in the afternoon session.

On receipt of the APN, all the Network Operators will reply to the RNO with an Acknowledgment to APN (AKAPN) to confirm the receipt of the APN sent by the RNO. The Network Operators should proceed the cutover on the agreed cutover date and time. The AKAPN should be replied to the RNO before 19:00 of the same day for NPRs in the morning session and before 19:00 of the next day for NPRs in the afternoon session.

- 4.1.4 The pre-provisioning activities of the RNO must not interfere with the existing routing of calls to and from the porting-in mobile customer who is still using the Donor Network.
- 4.1.5 If any difficulties are encountered by either the RNO or the DNO or other Network Operators that would jeopardize the achievement of the agreed cut-over date/time, then the case should be handled according to the Exceptional Cases for MNP Provision (see also Section 5).

## Completion Phase

- 4.1.6 For normal cases of MNP porting, the following process time should be complied by the Network Operators. For NPRs sent by RNO to DNO in the morning session (09:00-12:00) of Day 1, the whole process of porting should be completed by the mid-day cutover window (12:00-14:00) of Day 2. For NPRs sent by RNO to DNO in the afternoon session (12:00-18:00) of Day 1, the whole process of porting should be completed by the mid-night cutover window (01:00-04:00) of Day 3.
- 4.1.7 If the RNO does not identify any faults or receive any fault reports from other Network Operators by a specified period after the completion of the cutover window, then the RNO will consider the cutover as successful. The RNO will then send a Successful Completion of APN (SCAPN) to all the Network Operators to confirm the successful completion date/time of the cutover for record purpose.

## **4.2 Cut-over Procedures**

- 4.2.1 Prior to the start of cutover, as described in Section 4.1, each Network Operator will be responsible for having all deliverables ready for service.
- 4.2.2 The RNO will have completed all provisioning and pre-provisioning activities and all the Network Operators will have all the necessary number porting data in place prior to cutover.
- 4.2.3 Within the scheduled cutover time-window, the DNO will disconnect service for the customer and the RNO will commence service activation of the customer to its network. Within the same time window, the DNO, the RNO and all other Network Operators will effect a re-route on the routing plan of the ported number.
- 4.2.4 If the porting-in mobile customer is still busy within the time-window, the DNO may force-release the existing connection of this customer, without waiting for it to be idle, to carry out the cutover.
- 4.2.5 The physical cutover and the activation of routing plan are two independent activities and could be started and finished at any time within the agreed time-window.
- 4.2.6 The RNO is responsible for the successful completion of the cutover. If, for any reason, the cutover is unsuccessful, the case will be treated as a fault. The RNO will be responsible for resolving the fault, and the DNO and other Network Operators will work closely with it to solve the problem. The RNO is also responsible for notifying the porting-in customer of the status.
- 4.2.7 If the RNO does not identify any faults or receive any fault reports from other Network Operators by a specified period after the completion of the cutover window, then the RNO will consider the cutover as successful. After successful

cutover, the RNO will send a Successful Completion of APN (SCAPN) to all Network Operators for updating all necessary records.

### **4.3 Service termination of a ported number**

- 4.3.1 A ported number shall be regarded as relinquished when the customer's service has been terminated with the RNO for more than 3 months.
- 4.3.2 If a ported number is relinquished, the ported number should be returned to the Original DNO. This will be achieved by the RNO passing an Advice of Relinquished Ported Number (ARN) to the Original DNO and other Network Operators. The Original DNO will then be responsible for providing appropriate call handling treatment for that number in the same manner as other non-ported numbers.
- 4.3.3 Before the Original DNO assigns a relinquished number to a customer, it should ensure that at least one regular AD cross-auditing cycle has been completed successfully.

### **4.4 Successive porting of a number**

- 4.4.1 For a customer wishing to port the number from an old RNO to a new RNO, the procedures will be similar to those of initial porting of the number. The same procedures as specified in sections 4.1 and 4.2 above shall be followed. The new RNO will become the "Recipient Network Operator" and the old RNO will become the "Donor Network Operator". If a successively ported number eventually ceases to be used by that customer of the new RNO and thus the number is relinquished, the ported number should be returned to the Original DNO (see Section 4.3 above).
- 4.4.2 The procedure for porting back to the Original DNO should be similar to a normal porting case, except that the directory number should no longer be classified as a working ported number in the GN databases and the Administration Databases.

## **5. Fault handling procedures**

- 5.1 Each Network Operator will progress their own fault handling within their own operations. If a fault requires joint investigation or the co-ordination of fault handling, Network Operators should follow the document named Exceptional Cases for MNP Provision to rectify the faults.
- 5.2 Each Network Operator will be responsible for their own customer base and as such will have control of any service fault reports. For ported numbers, fault handling for the ported number will be under the control of the RNO, although

additional co-ordination may be required with the DNO. Such co-ordination and fault handling should follow the Exceptional Cases for MNP Provision. The RNO will work closely with the DNO and the other Network Operators to resolve any fault reports.

## **6. Numbering Allocations**

### **6.1 Gateway Number**

6.1.1 The Gateway Number (GN) refers to the called address which is sent through the Point of Interconnect (POI) during call set up. For ported number calls, the GN is sent instead of the ordinary Directory Number (DN).

6.1.2 Blocks of GN will be allocated to each mobile Network Operator by the TA and the responsibility for individual GN assignment and notification will fall on the RNO (please refer to Annex B for GN allocation). The TA will administer the allocation of GN blocks based on the actual requirements of the Mobile Network Operators.

6.1.3 The format of the GN will be determined by the RNO, format as follows:

Network Number (NN) (max. 12 digits)

For example: 481 XXXXXXXXXX

Number block(s) of NN will be allocated by the TA for this purpose. The NN is designed to be a separate domain from the Directory Number.

6.1.4 The Originating Network or Transit Network should be capable of sending any one of the above formats to the Recipient Network. The Transit Network will repeat the GN without change to the Recipient Network.

### **6.2 Administration**

The TA will administer the assignment and allocation of Network Number (NN). Details of the assignment and allocation plans are given in Annex B.

### **6.3 Change of GN**

Once a mobile number has been successfully ported to the RNO, the RNO must maintain the same GN until service is terminated or the mobile number is further ported to other network operators. If the RNO cannot maintain the same GN, the change of GN should be allowed and the agreed procedure for change of GN should be followed. However, the cost to the requesting party

for the change of GN is subject to commercial negotiation between Network Operators which is outside the scope of this document.

## **7. Performance Requirements**

### **7.1 Additional call set-up delay time due to number portability**

The additional call set-up delay time due to implementation of MNP should have a mean value of 3 seconds or less, and for 95% of the calls this value should not exceed 3.75 seconds.

### **7.2 Number Porting Capacity**

- 7.2.1 Every Network Operator should ensure that its MNP Provider(s) and MA(s) should implement their systems and procedures to support not less than a total of 5,000 ported numbers per day from the initial launch of MNP.
- 7.2.2 Network Operators' requests for number porting should be handled by all Network Operators on a first-come-first-served principle. The system for operating this principle and controlling capacity utilization should follow the document named MNP Capacity Control Requirement.
- 7.2.3 The TA, according to the market need and requirement, would make appropriate revision to the number porting capacity if necessary.

**List of Annexes**

Annex A Information Exchange

Annex B Gateway Number Allocation

Annex C Functional Requirements of Administration Database

## **Annex A - Information Exchange**

The production and exchange of all information to/from each Network Operator to complete mobile number portability data processing is provided during the activation process mentioned in section 4.1. During the process, the RNO will advise the DNO that a mobile number will be ported. The RNO will have to distribute an Advice of Portable Number (APN) to all MAs. This APN will act as common advice for the Network Operators to build their routing and numbering plan. The APN must be recorded and maintained by the Network Operators.

The following information had to be included in the APN:

- APN serial number assigned by Recipient Network
- Directory Number of the Ported Number
- Corresponding Gateway Number which is assigned by the Recipient Network Operator
- Time and date of changeover
- Donor Network Operator
- Recipient Network Operator
- Original DNO
- service details relating to the ported number

The detailed functional requirements for the implementation of the de-centralized administration database and the associated communication link requirement is given in Annex C and the HKTA 2104 - Functional Specification of Administration Database for Mobile Number Portability.

## **Annex B - Gateway Number Allocation**

Instead of sending the original customer Directory Number (DN) through the Point of Interconnection (POI), the Gateway Number (GN) is delivered from one network to the other for implementation of mobile number portability by database solution. The format of the GN is as follows :

Network Number (NN) (max. 12 digits)

NN will contain the leading digit '4' and is a number for routing purpose. Details of the allocation are given below:

480X.....X	Hutchison	GSM900
481X.....X	Hutchison	GSM1800
482X.....X	CWHKTCSL	DAMPS
483X.....X	SmarTone	GSM900
484X.....X	SmarTone	GSM1800
485X.....X	PEOPLES	GSM1800
486X.....X	Hutchison	CDMA
487X.....X	NWPCS	GSM1800
488X.....X	CWHKTCSL	GSM900
489X.....X	CWHKTCSL	GSM1800
490X.....X	SUNDAY	GSM 1800

where X---X is maximum 9 digits long depending on the Network Operator's assignment

The GN is designed to be a number domain totally separated from the domain of the conventional customer Directory Number (DN).

**Annex C - Functional Requirements of Administration Database (AD)**

**Contents**

- 1. Introduction**
- 2. Requirements of Administration Database (AD)**
- 3. Inter-AD Communication Network**
- 4. Network Security**
- 5. Communication Network Setup, Administrations and Maintenance**
- 6. Information Exchange File (INF)**
- 7. Information Exchange Document (IED)**
- 8. IED Type**
- 9. Information Exchange Procedure**
- 10. Information Exchange Protocol**
- 11. Information Exchange Protocol for Change of Gateway Number**
- 12. Cross-auditing of ADs**

## 1. Introduction

- 1.1 In addition to the real-time GN database residing in the switching network of the Network Operators and MNP Providers, a decentralized database (hereafter referred as to **Administration Database (AD)**) is found essential to facilitate mobile number portability (MNP) by database solution.
- 1.2 The major function of the AD is to maintain the data integrity of the records kept by individual Network Operator. It also serves as a backup for the recovery of the GN Database and other ADs in case of disaster.
- 1.3 This document specifies the structure of the AD, its record format, the Information Exchange File format, inter-AD communication network for file transfer and the communication protocol used.
- 1.4 Every Network Operator should nominate one or more MNP Provider(s) and a MA(s), which may be the Network Operator itself. The Network Operator should ensure proper coordination between its MNP Provider(s) and its MA(s).
- 1.5 A MA or MNP Provider may serve more than one Network Operator.
- 1.6 Detailed requirements for implementing the AD system should be referred to the HKTA 2104 - Functional Specification of Administration Database for Mobile Number Portability.

## 2. Requirements of Administration Database

- 2.1 Each Network Operator is required to either set up and maintain an AD or use the AD(s) operated by its MA(s). The objectives are first to maintain data integrity among Network Operators for number portability and, secondly, to act as backup reference for disaster recovery in case of breakdown of any of the ADs.
- 2.2 The AD is decentralized in the sense that all AD copies are of the same content, but physically duplicated since each Network Operator or its MA(s) has a copy of it.
- 2.3 The AD stores all the working ported-in and ported-out numbers together with their corresponding information. History records are retained in the AD for at least 6 months . Numbers that have never been ported will not have records stored in the AD.

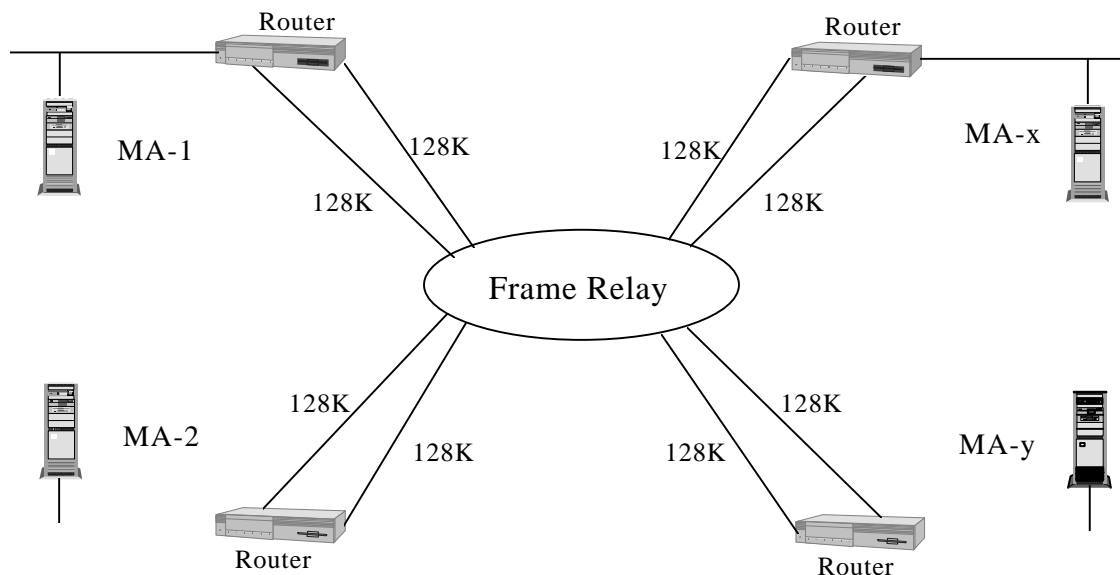
2.4 The following table shows the AD record format.

AD Field
Directory Number
Gateway Number
Recipient Network Operator (RNO)
Donor Network Operator (DNO)
Original DNO
Original Type of Service
Existing Type of Service
Changeover Date
Termination Date
RNO/DNO Reference Serial Number

### 3. Inter-AD Communication Network

3.1 The communication among the AD systems are via data-links by Frame Relay Permanent Virtual Circuits (PVCs). Please refer to Figure 1 below for a conceptual topology of the inter-AD communication network.

**Figure 1- Inter-AD Communication Network Configuration**



ANCF1.PPT

### 4. Network Security

4.1 Each MA should only allow access to its AD servers by other Network Operators or MAs by establishing a scheme of user identity (ID) and password. The Network Operators or MAs holding this information should keep it in confidence, including authorizing access to staff on a need-to-know basis only.

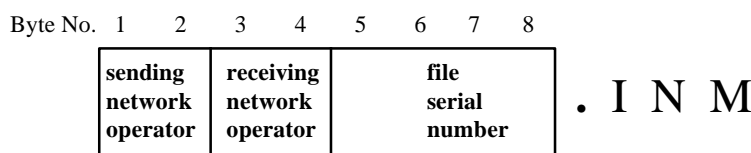
- 4.2 Each Sending Network Operator will assign a specific working directory in its AD server for information to be retrieved by each Receiving Network Operator. On retrieval of information from the other AD servers, the MA should only read the directories assigned to itself or its client Network Operators.

**5. Communication Network Setup, Administration and Maintenance**

- 5.1 Each MA should setup, administer and maintain its own AD server(s), router(s) and communication links.
- 5.2 The router(s) used should be compatible with those of other Network Operators or their MAs.
- 5.3 Addresses and masks employed should be reconciled among all Network Operators or MAs.
- 5.4 The Internet Protocol (IP) addresses and masks of the AD servers and routers, together with the Frame Relay Data Link Connection Identifier (DLCI) of the data-links, should be given to all other MAs and kept confidentially. User IDs and passwords for accessing the working directories should be given to the respective Network Operators or MAs.

**6. Information Exchange File (INF)**

- 6.1 Information exchange among the Network Operators or their MAs is achieved by means of Information Exchange Files (IEF) transferred through the communication network. There is a series of Information Exchange Documents (IED) inside each INF. The IEDs received are used to update the AD.
- 6.2 INFs are sent and received for the purposes of exchange of information during the negotiation phase, the provisioning phase, the completion phase and the termination phase.
- 6.3 The file name of an INF should adopt the following format:



1st - 2nd byte :            Sending Network Operator  
(TC - HKTC)

- TI - reserved for HKTI
- HC - Hutchison Communications
- NW - New World Telephone
- NT - New T&T
- TG - CWHKTCSL GSM
- TM - CWHKTCSL DAMPS
- HG - Hutchison GSM
- HD - Hutchison CDMA
- SG - SmarTone GSM
- SP - SmarTone PCS
- NP - New World PCS
- MP - Mandarin (Sunday) PCS
- PP - Peoples PCS)

3rd - 4th byte :       Receiving Network Operator  
(see Sending Network Operator)

5th - 8th byte:       File Serial Number (start from 0001 )

file extension:       INM for information exchange files

6.4 For instance, SGTG0002.INM is the second information exchange file sent from SmarTone GSM to HKTCSL GSM.

6.5 The INF has the following file format:

Header Document	IED #1	IED #2	.....	EOF
-----------------	--------	--------	-------	-----

6.6 Each INF contains a Header Document at the beginning of the file with the following fields:

Header Fields
File Type
Creation Date
Sending Network Operator
Receiving Network Operator
Total Number of IED Enclosed
<Carriage Return>

## 7. Information Exchange Document (IED)

- 7.1 Each IED has the following format. Except for the 'Comment' field, all fields are mandatory. Normally, only one IED within an INF is needed for the porting of one directory number.

<b>I E D</b>
IED Type ( see 8. below )
Directory Number (DN)
Gateway Number (GN)
Recipient Network Operator (RNO)
Donor Network Operator (DNO)
Original DNO
Original Type of Service
Existing Type of Service
Changeover Start Date
Changeover Start Time
Changeover End Time
RNO/DNO Reference Serial Number
Number of Document in a RNO/DNO Reference Serial Number
Name
ID Number / Passport Number
Comment
<Carriage Return>

## 8. IED Type

- 8.1 There are 11 IED Types:

- i) NPR (Number Portability Request)
- ii) NTNPR (Negotiation of NPR)
- iii) AKNPR (Acknowledgment to NPR)
- iv) CLNPR (Cancellation of NPR)
- v) ACNPR (Acknowledgment to CLNPR)
- vi) APN (Advice of Porting Number)
- vii) AKAPN (Acknowledgment to APN)
- viii) CLAPN (Cancellation of APN)
- ix) ACAPN (Acknowledgment to CLAPN)
- x) SCAPN (Successful Completion of APN)
- xi) ARPN (Advice of Relinquished Porting Number)

## 9. Information Exchange Procedure

- 9.1 Information exchange files should be retrieved based on 30 minutes polling interval.

- 9.2 During a write cycle, the sending network operator should write the document files on to its directory for a receiving network operator. The sending network operator should write document files in sequence together with a control file for that receiving network operator. While a document file or a control file is being updated or created, reading of the file by the receiving network operator should be blocked or disabled so that no partial or incomplete file will be received by the receiving network operator.
- 9.3 In case the 'Total Number of IED Enclosed' in the header document of a received INF does not match with the IEDs appended in the INF, the Receiving Network Operator should request the Sending Network Operator to retransmit the corrupted INF.

**10. Information Exchange Protocol**

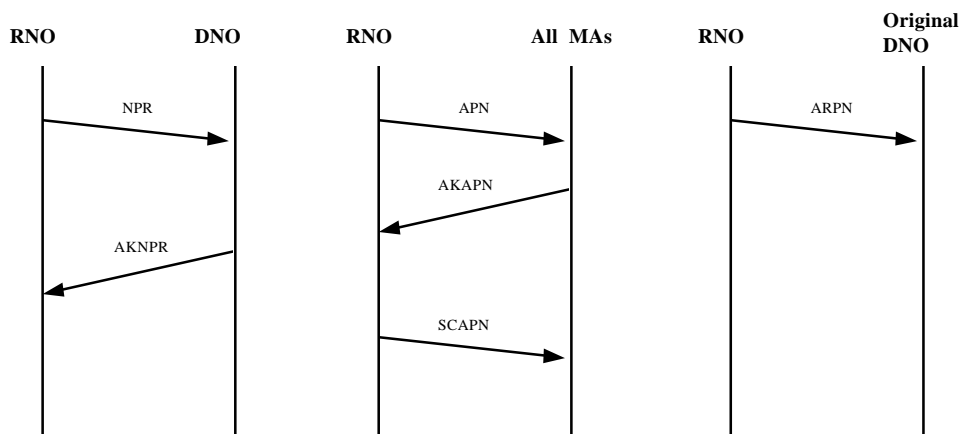


Figure 2 - Negotiation Phase, Successful Negotiation

Figure 3 - Provisioning Phase, Successful Provision

Figure 4 - Relinquishment of Ported Number to Original DNO

**11. Information Exchange Protocol for Change of Gateway Number**

- 11.1 The protocol is similar to that of porting numbers. The RNO and DNO fields in the IED will indicate the same Network Operator. There is only provisioning phase in the protocol and the RNO should initiate the change by first sending out an APN at least 24 hours in advance of the expected cut-over date.

**12. Cross-auditing of ADs**

**General**

- 12.1 In order to eliminate data discrepancy among the ADs, a cross-auditing exercise is carried out every month.

- 12.2 Every MA should sort its AD using RNO as the key and generate different audit files. All working records should be included. For history records, only those generated in the previous month should be included.
- 12.3 The audit files should then be sent via the communication network to the corresponding RNO for auditing.
- 12.4 After receiving the audit file, the RNO will request its MA to compare all records inside the file with the records of its AD.

**Cross-auditing Discrepancies Found**

- 12.5 In case mismatch record arises, the RNO should take full responsibility to investigate and rectify the mismatch record and then inform the sending MAs for updating their ADs.
- 12.6 The following are the possible scenarios of mismatch between records received from the sending MA and the records in the AD of RNO:

Scenario	Action
Sending MA record have no corresponding record in the AD of the RNO	delete record in the sending MA's AD
RNO's AD record not in audit file	add record in the sending MA's AD
Content mismatch between the sending MA record and record in the AD of the RNO	update record in the sending MA's AD

**Cross-auditing No Discrepancies Found**

- 12.7 If no discrepancy is found, a rectification file should still be sent to the sending MA as confirmation of successful audit.

**Cross-auditing File Format**

- 12.8 The audit file, the rectification file, the verification file, and their corresponding header document have the following format:

Header Document	record #1	record #2	.....	EOF
-----------------	-----------	-----------	-------	-----

Header Fields
File Type
Verification Date
Sending Network Operator
Receiving Network Operator
Total Number of Records Enclosed
<Carriage Return>

- End of Document -